



**КОВАЧЪ**  
www.kovachy.ru



**ROLLERI**<sup>®</sup>  
INNOVATIVE TOOLS

# CLAMPING SYSTEMS

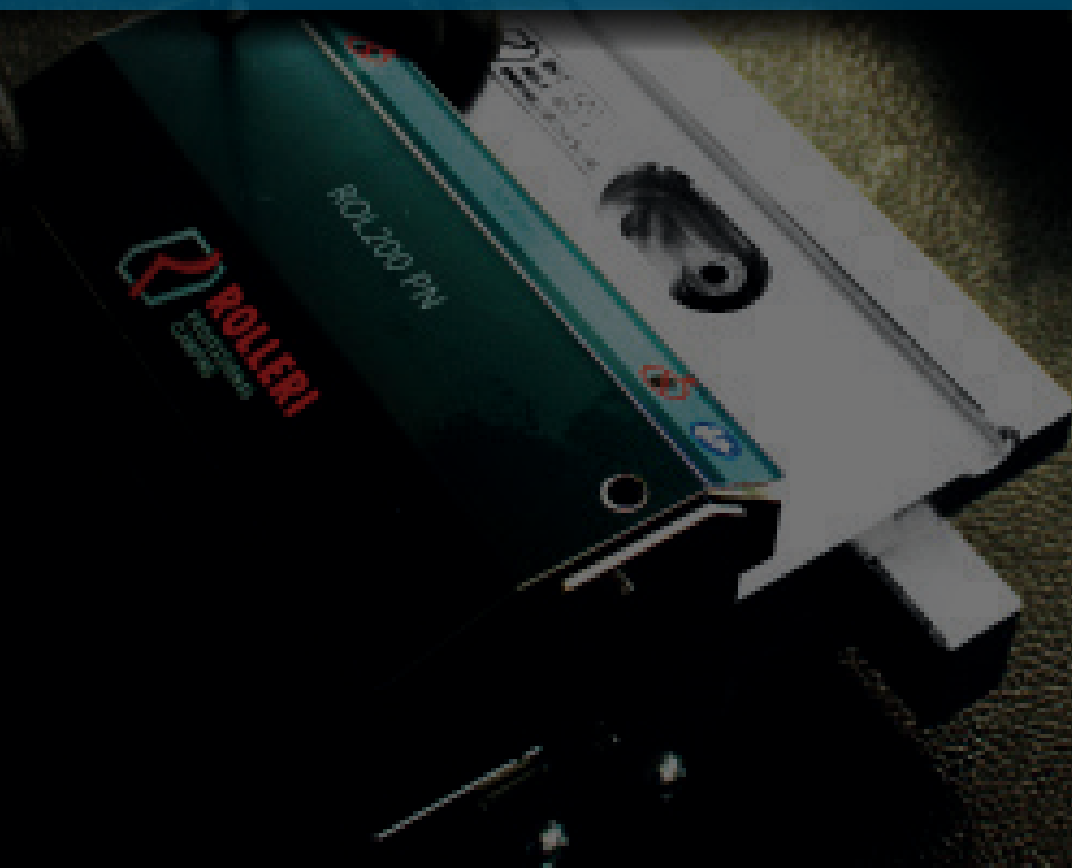



CONTROL UNITS

10 - 11



12 - 61

INTERMEDIATES	14 - 17
CLAMPS	18 - 19
ROL200	20 - 29
ROL4	30 - 33
FAST CLAMP	34 - 41
EASY CLAMP	42 - 49
LOWER CLAMP	50 - 51
ROL2	52 - 59
CTS	60 - 61

R1



62 - 69

W ROL	64 - 67
W ROL 2	68 - 69

R2



70 - 75

ROL3	72 - 75
------	---------

R3  
R4  
RX



76 - 83

INTERMEDIATES	78 - 79
UNIVERSAL FAST CLAMP	80 - 81
UNIVERSAL EASY CLAMP	82 - 83

R  
Am

CROWNING TABLE

84 - 91

TAB

ABOUT US  
SPECIAL APPLICATIONS

92 - 98

## ▼ COMPATIBILITY

# R1

Check icon 

- ▶ Accurl
- ▶ Accurpress
- ▶ ACL
- ▶ Adira
- ▶ Amada
- ▶ Atlantic
- ▶ Baykal
- ▶ BL
- ▶ Boschert
- ▶ Boutillon
- ▶ Bystronic Beyeler
- ▶ Euro-B
- ▶ Coastone
- ▶ Colgar
- ▶ Dener
- ▶ Deratech
- ▶ Durmazlar
- ▶ Ermaksan
- ▶ Farina
- ▶ Gade
- ▶ Gasparini
- ▶ Gecko
- ▶ Gilardi
- ▶ Gizelis
- ▶ Haco
- ▶ Hindustan
- ▶ HPM
- ▶ Iturrospe
- ▶ Jfy
- ▶ JMT
- ▶ LFK
- ▶ Metfab
- ▶ MVD
- ▶ Oriance
- ▶ Prima Power
- ▶ Promecam
- ▶ Rico
- ▶ Salvagnini
- ▶ Schiavi
- ▶ SMD
- ▶ Sorg
- ▶ Somo
- ▶ Vicla
- ▶ Vimercati
- ▶ Warcom
- ▶ Yawei
- ▶ etc.

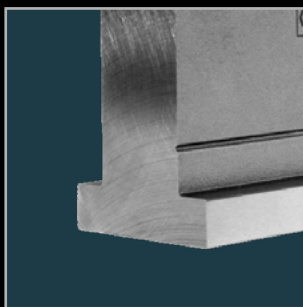
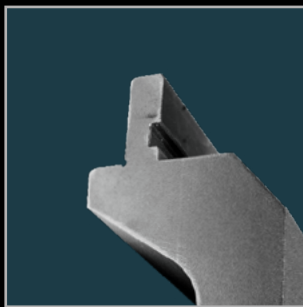



# R2

Check icon 

- ▶ Darley
- ▶ LVD
- ▶ Safan
- ▶ Trumpf
- ▶ Press brake machines with System NSCL

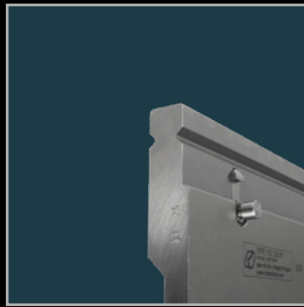

# R3

Check icon 

Bystronic Beyeler:

- ▶ RFA
- ▶ RF
- ▶ R
- ▶ S

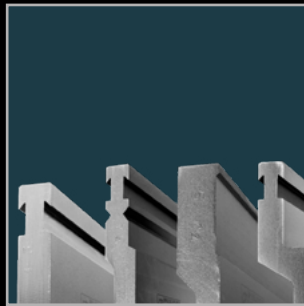

- ▶ Bystronic Beyeler
- ▶ Darley
- ▶ Safan
- ▶ SMD
- ▶ Trumpf
- ▶ Press brake machines with System NSCR

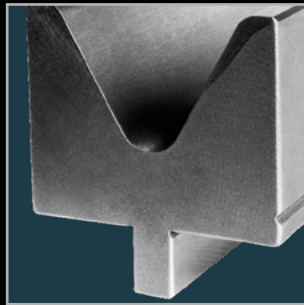

Check icon 

# R4

- ▶ LVD

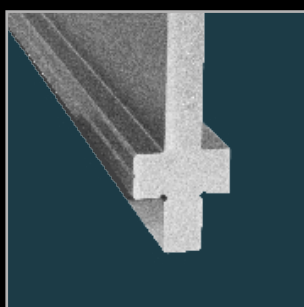
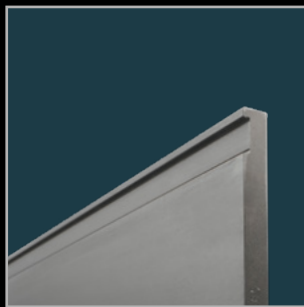

Check icon 

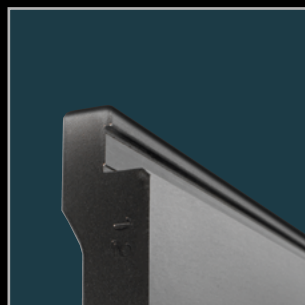

# RX

- ▶ Ajjal-Axial
- ▶ Colgar
- ▶ Colly
- ▶ EHT
- ▶ Ursviken
- ▶ Weinbrenner



Check icon  → Patented Product

### OTHER **ROLLERI** CATALOGUES:

- ▶ PRESS BRAKE TOOLS
- ▶ PRESS BRAKE TOOLS  American
- ▶ PRESS BRAKE TOOLS  Hämmerle-Bystronic
- ▶ PUNCHING TOOLS
- ▶ IRON WORKER
- ▶ LASER CONSUMABLES
- ▶ INDUSTRIAL EQUIPMENT
- ▶ CRIMPING MACHINES



## Rolleri Tools Type

R1

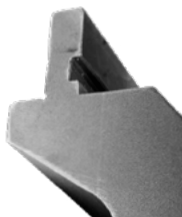

ACL, Accurpress, AM Machinery, Amada, Atlantic, Adira, Baykal, BL, Boschert, Boutillon, Bystronic-Beyeler Euro-B, Coastone, Colgar, Dener, Deratech, Durmazlar, Ermaksan, Farina, Gade, Gasparini, Gizelis, Haco, Hindustan, Iturraspe, Jfy, JMT, LFK, Metfab, MVD, Oriance, Prima Power, Promecam, Rico, Salvagnini, Schiavi, SMD, Sorg, Somo, Vicla, Vimercati, Warcom, Yangli, Yawei, Ysd, etc.

R2



LVD, Trumpf, Darley, Safan or press brakes with System NSCL  
(New Standard Clamping)

R3

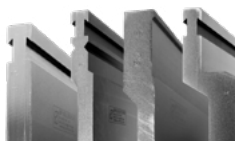

Bystronic-Beyeler RFA  
Bystronic-Beyeler RF  
Bystronic-Beyeler R  
Bystronic-Beyeler S

R4



LVD

RX

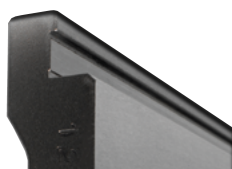

Ajial-Axial, Colgar, Colly, EHT, Ursviken, Weinbrenner

R American



American

# Clamping Type



TOOLS	CLAMPING ROLLERI	UPPER SIDE	LOWER SIDE	VERTICAL CHANGE	HORIZONTAL CHANGE	PNEUMATIC VERSION	HYDRAULIC VERSION	MANUAL VERSION
R1	ROL200 KDS	●		●	●	●	●	
R1	ROL200	●		●		●	●	●
R1	ROL4	●			●		●	●
R1	FAST CLAMP	●		●	●			●
R1	DOUBLE FAST CLAMP	●		●	●			●
R1	EASY CLAMP	●			●			●
R1	DOUBLE EASY CLAMP	●			●			●
R1	ROL2		●			●	●	●
R2	W ROL	●		●	●	●	●	
R2	W ROL 2		●			●	●	
R3 R4 RX	ROL3	●●●●		●●●●	●●●●		●●●●	
R American	UNIVERSAL FAST CLAMP	●		●				●
R American	UNIVERSAL EASY CLAMP	●			●			●

## Control Units

	PDU MOLT	HPU-E	HPU-E/30	HPU-E/80
ROL200 KDS PN	●			
ROL200 KDS HYD				●
ROL200 PN	●			
ROL200 HYD				●
ROL4 HYD		●		
ROL2 HYD		●		
ROL2 PN	●			
W ROL PN	●			
W ROL HYD			●	
W ROL2 PN	●			
W ROL2 HYD			●	
ROL3 HYD		●●●		

### PDU MOLT

- ▶ BASIC VERSION
- ▶ SET OF PNEUMATIC COMPONENTS
- ▶ MADE TO POWER ONE SINGLE SYSTEM
- ▶ WITH MULTIPLIES AIR

Independent Hydraulic control unit  
available on request

[sales@rolleri.it](mailto:sales@rolleri.it)

### HPU-E

- ▶ TO BE CONNECTED TO CNC FOR OPEN-CLOSE FUNCTION
- ▶ GIVES ELECTRIC SIGNAL TO CNC IN CASE OF LOWERING PRESSURE, SETTING PRESS BRAKE IN ALARM STOP
- ▶ WORKS ON 220-380 VOLT
- ▶ PRESSURE 160 BAR
- ▶ 15 LIT OIL PUMP

### HPU-E/80 HPU-E/30

- ▶ TO BE CONNECTED TO CNC FOR OPEN-CLOSE FUNCTION
- ▶ GIVES ELECTRIC SIGNAL TO CNC IN CASE OF LOWERING PRESSURE, SETTING PRESS BRAKE IN ALARM STOP
- ▶ WORKS ON 220-380 VOLT
- ▶ PRESSURE 80 BAR/ PRESSURE 30 BAR
- ▶ 15 LIT OIL PUMP



	ROL2 PN	W ROL 2 PN	ROL2 HYD
ROL200 PN	PDU 2 MOLT.	PDU 2 MOLT.	PDU MOLT + HPU-E
W ROL PN	PDU 2 MOLT.	PDU 2 MOLT.	PDU MOLT + HPU-E
W ROL HYD	HPU-E/30 + PDU MOLT.	HPU-E/30 + PDU MOLT.	HPU-E_2
ROL200 HYD	PDU MOLT. + HPU-E/80	PDU MOLT. + HPU-E/80	HPU-E_2
ROL4 HYD	PDU MOLT. + HPU-E	PDU MOLT. + HPU-E	HPU-E_2
ROL3 HYD	Subject to technical study	Subject to technical study	Subject to technical study

### PDU 2 MOLT

- ▶ CONTROLS AIR PRESSURE AT ENTRANCE & AT END OF LINE OF CIRCUIT
- ▶ MULTIPLIES AIR FROM COMPRESSOR TO ENSURE BEST CLAMP CLOSURE
- ▶ GIVES ELECTRIC SIGNAL TO CNC IN CASE OF LOWERING PRESSURE, SETTING PRESS BRAKE IN ALARM STOP
- ▶ PDU2 MOLT FOR TWO SYSTEMS

### HPU-E\_2

- ▶ TO BE CONNECTED TO CNC FOR OPEN-CLOSE FUNCTION
- ▶ GIVES ELECTRIC SIGNAL TO CNC IN CASE OF LOWERING PRESSURE, SETTING PRESS BRAKE IN ALARM STOP
- ▶ WORKS ON 220-380 VOLT
- ▶ PRESSURE 160 BAR

### PDU MOLT TOP

- ▶ CONTROLS AIR PRESSURE AT ENTRANCE & AT END OF LINE OF CIRCUIT
- ▶ MULTIPLIES AIR FROM COMPRESSOR TO ENSURE BEST CLAMP CLOSURE
- ▶ GIVES ELECTRIC SIGNAL TO CNC IN CASE OF LOWERING PRESSURE, SETTING PRESS BRAKE IN ALARM STOP
- ▶ SUPPLIED IN A CABINET
- ▶ ROL1 PDU2 MOLT TOP FOR TWO SYSTEMS

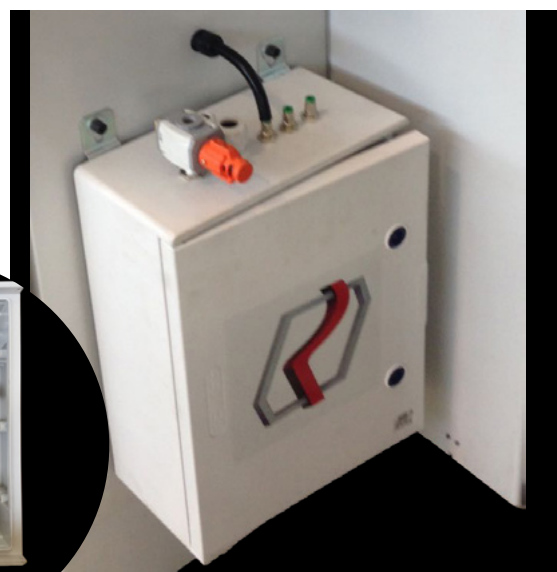
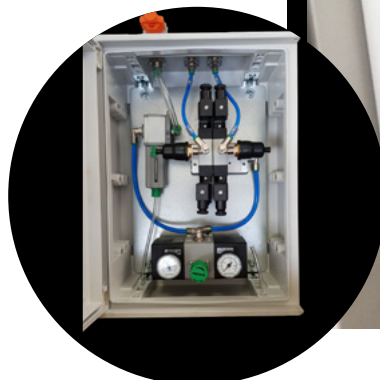



## SYSTEMS FOR ROLLERI TOOLS RI

### ▼ COMPATIBILITY

Accurl  
Accurpress  
ACL  
Adira  
Amada  
Atlantic  
Baykal  
BL  
Boschert  
Boutillon  
Bystronic Beyeler  
Euro-B  
Coastone  
Colgar  
Dener  
Deratech

Durmazlar  
Ermaksan  
Farina  
Gade  
Gasparini  
Gecko  
Gilardi  
Gizelis  
Haco  
Hindustan  
HPM  
Iturrospe  
Jfy  
JMT  
LFK  
Metfab

MVD  
Oriance  
Prima Power  
Promecam  
Rico  
Salvagnini  
Schiavi  
SMD  
Sorg  
Somo  
Vicla  
Vimercati  
Warcom  
Yawei  
etc.



**UPPER**

Intermediates	14 - 17
Clamps	18 - 19
ROL200	20 - 29
ROL4	30 - 33
FAST CLAMP	34 - 41
EASY CLAMP	42 - 49

**LOWER**

Clamps	50 - 51
ROL2	52 - 59
CTS	60 - 61

## Intermediates

	INT 100 FISSO	INT 100 *	INT 120 *	INT 150 *	INT 120-40	INT 132-40	INT 150-40	INT 120 HD	INT 150 HD	INT 120-40 HD	INT 150-40 HD
ROL200 KDS PN			●	●			●	●			
ROL200 KDS HYD			●	●							
ROL200 MAN	●	●	●	●	●	●	●	●	●	●	●
ROL200 PN			●	●		●	●	●	●	●	●
ROL200 HYD			●	●				●	●	●	●
ROL4 HYD	●	●	●	●		●	●	●	●	●	●
ROL4 MAN	●	●	●	●	●	●	●	●	●	●	●
FAST CLAMP1	●	●	●	●	●						
DOUBLE FAST CLAMP1	●	●	●	●	●						
FAST CLAMP3	●	●	●	●	●						
DOUBLE FAST CLAMP3	●	●	●	●	●						
EASY CLAMP	●	●	●	●	●	●	●	●	●	●	●
DOUBLE EASY CLAMP	●	●	●	●	●	●	●	●	●	●	●

\* Available also version without crowning wedge

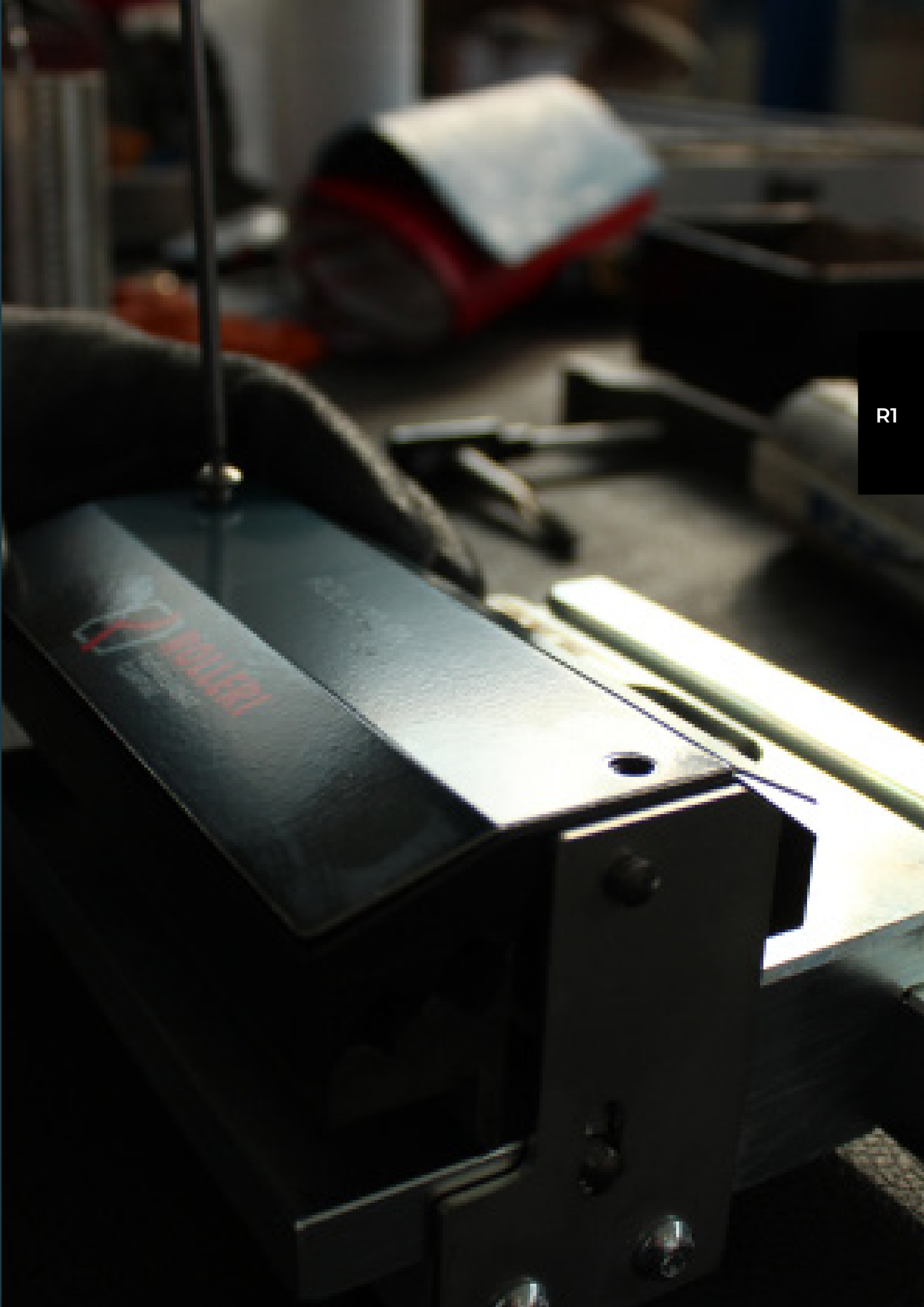

# Intermediates

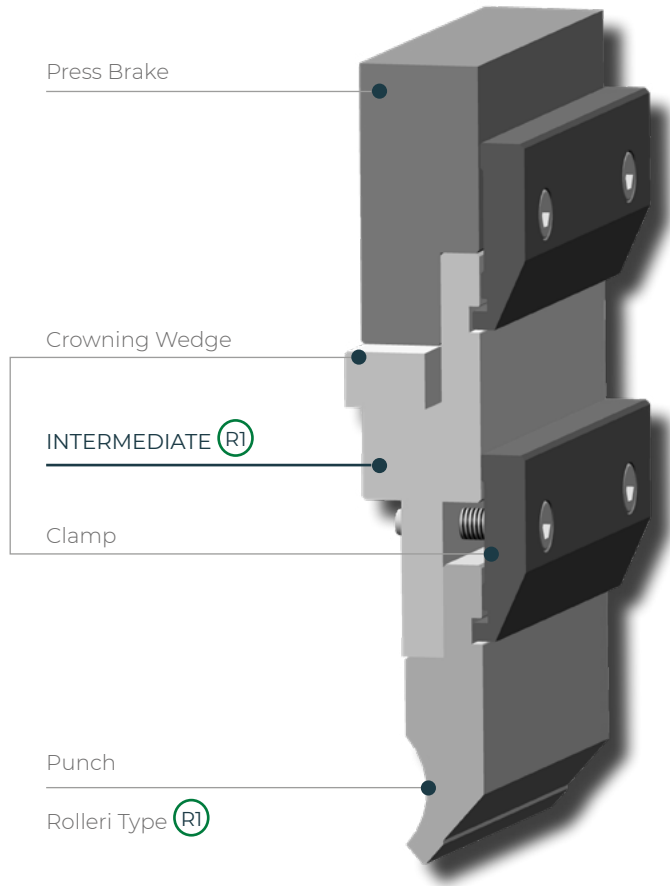

C45: 560-710 N/mm<sup>2</sup> 1000 kN/m max.

## AD4

150 mm | 1.8 kg

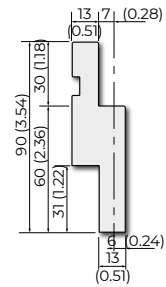

Punch extension  
without crowning  
wedge



C45: 560-710 N/mm<sup>2</sup> 1000 kN/m max.

## INT100 FISSO

150 mm | 4.0 kg

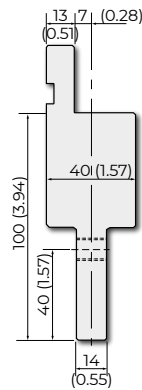

Punch extension  
without crowning  
wedge



C45: 560-710 N/mm<sup>2</sup> 1000 kN/m max.

## INT100

150 mm | 3.5 kg

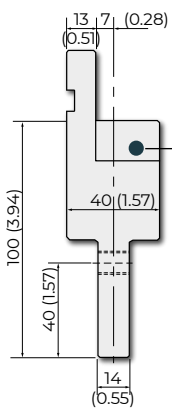

crowning  
wedge



C45: 560-710 N/mm<sup>2</sup> 1000 kN/m max.

## INT120 \*

150 mm | 4.5 kg

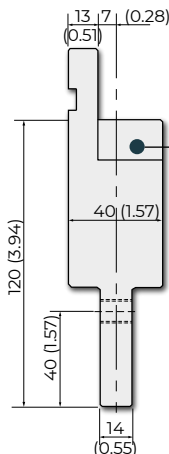

Intermediates  
available upon  
request also in L=70  
mm.

crowning  
wedge



C45: 560-710 N/mm<sup>2</sup> 1000 kN/m max.

## INT150 \*

150 mm | 5.9 kg

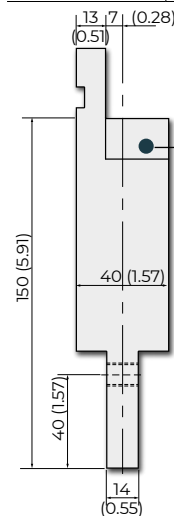

crowning  
wedge



\* Available also version without crowning wedge



C45: 560-710 N/mm<sup>2</sup> 1000 kN/m max.

### INT120-40

150 mm 5.2 kg

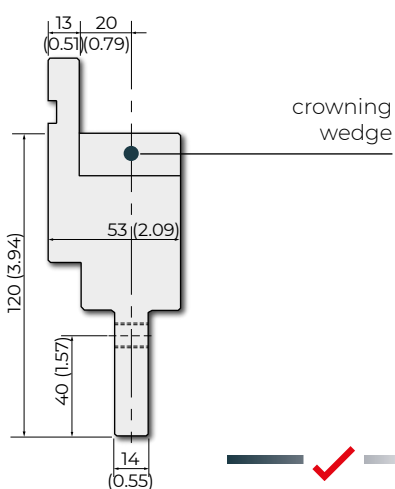

C45: 560-710 N/mm<sup>2</sup> 1000 kN/m max.

### INT132-40

150 mm 8.0 kg

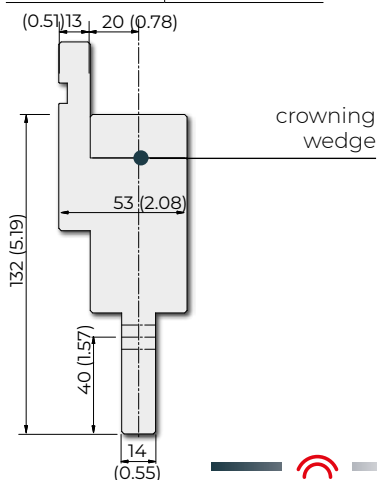

C45: 560-710 N/mm<sup>2</sup> 1000 kN/m max.

### INT150-40

150 mm 8.0 kg

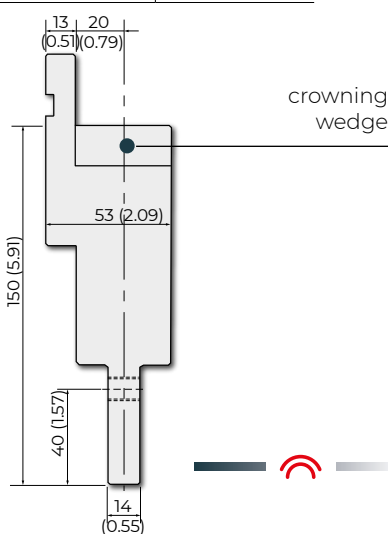

R1

42Cr: 900-1150 N/mm<sup>2</sup> 1600 kN/m max.

### INT120 HD

150 mm 4.5 kg

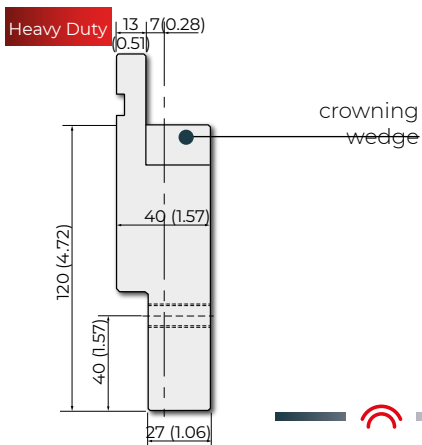

42Cr: 900-1150 N/mm<sup>2</sup> 1600 kN/m max.

### INT150 HD

150 mm 6.7 kg

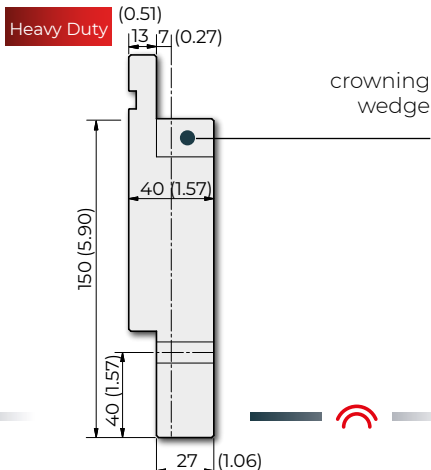

42Cr: 900-1150 N/mm<sup>2</sup> 1600 kN/m max.

### INT120-40 HD

150 mm 5.2 kg

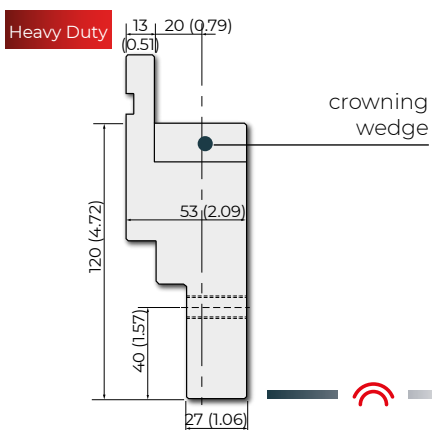

42Cr: 900-1150 N/mm<sup>2</sup> 1600 kN/m max.

### INT150-40 HD

150 mm 7.5 kg

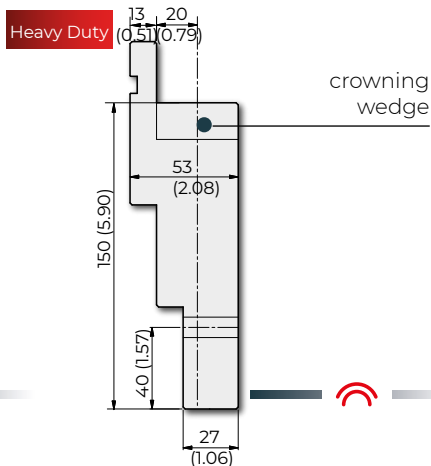

# Clamps

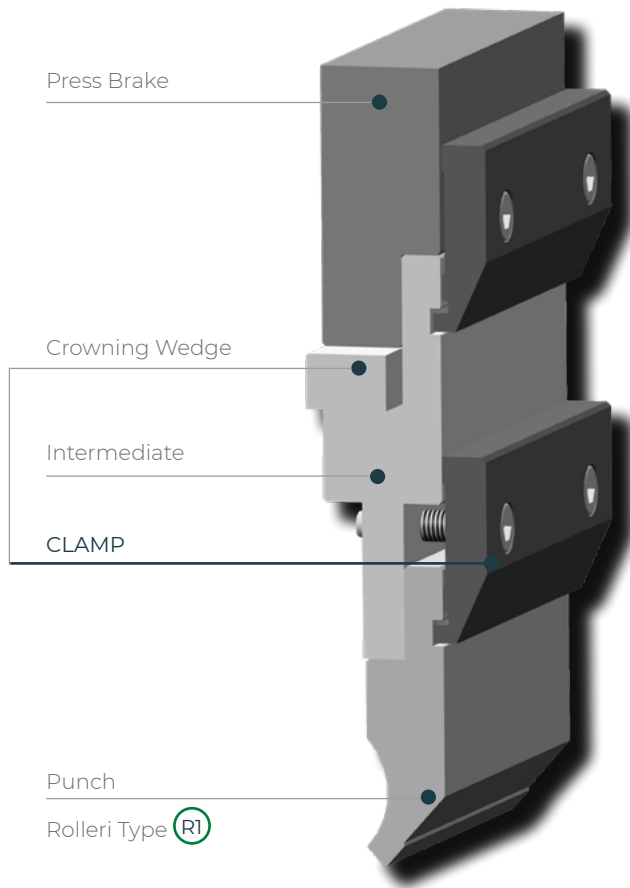

- ▶ Clamping Systems enable fast horizontal tool change
- ▶ Plastic Pressure Strip improves clamping especially with short tool segments

Needed clamps	Length of press brake
4 pieces	835 mm
6 pieces	1250 mm
11 pieces	2100 mm
14 pieces	2600 mm
16 pieces	3100 mm
21 pieces	4100 mm

Fe37: 370-470 N/mm<sup>2</sup>

ST50 / ST50R / STG50		
ST50	150 mm	0.70 kg
ST50R	150 mm	0.50 kg
STG50	150 mm	0.70 kg

Fe37: 370-470 N/mm<sup>2</sup>

ST60 / ST60R / STG60		
ST60	150 mm	0.80 kg
ST60R	150 mm	0.85 kg
STG60	150 mm	0.80 kg

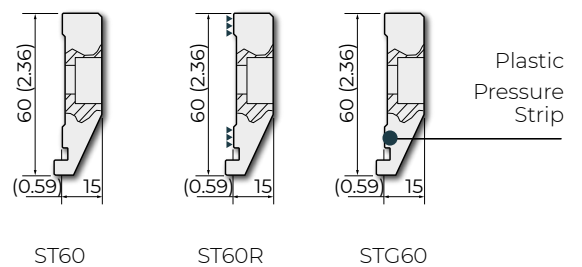
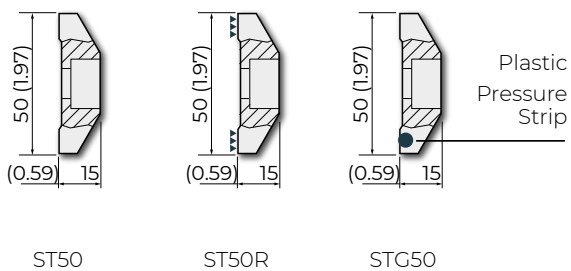
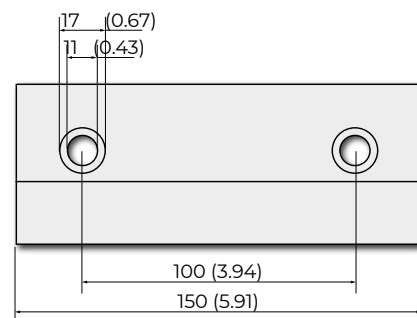
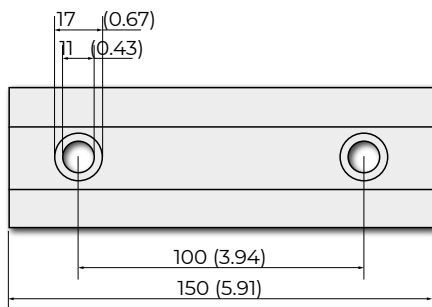



Fe37: 370-470 N/mm<sup>2</sup>

**STL60 / STL60R / STL60G**

STL60	150 mm	1.00 kg
STL60R	150 mm	0.80 kg
STL60G	150 mm	1.00 kg

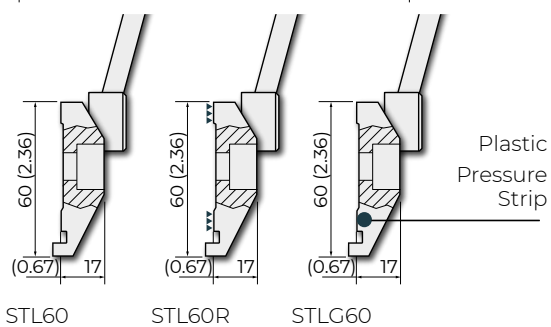
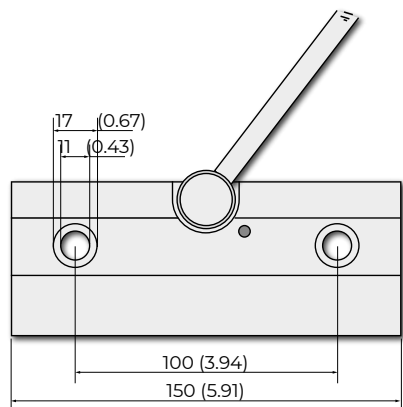

Fe37: 370-470 N/mm<sup>2</sup>

**STX60 / STX60R / STX60G**

STX60	150 mm	0.85 kg
STX60R	150 mm	0.50 kg
STX60G	150 mm	1.00 kg

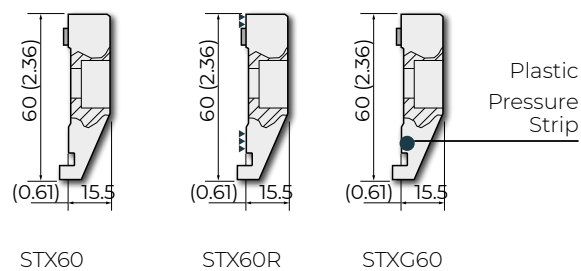
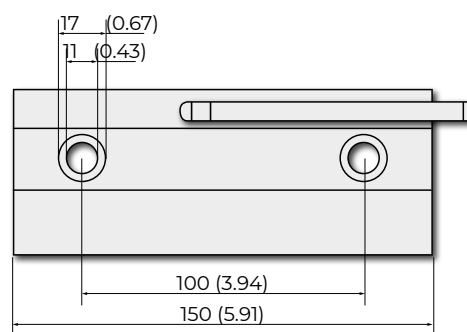

R1

Fe37: 370-470 N/mm<sup>2</sup>

**KDS**

150 mm | 0.5 kg

Intermediate

Crowning

Wedge

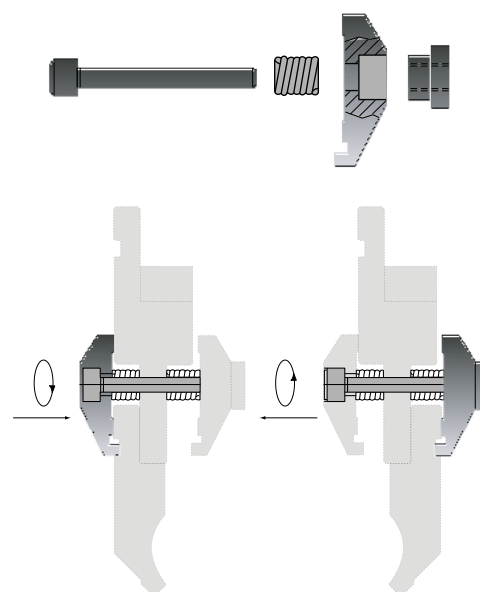

Clamp

Intermediates

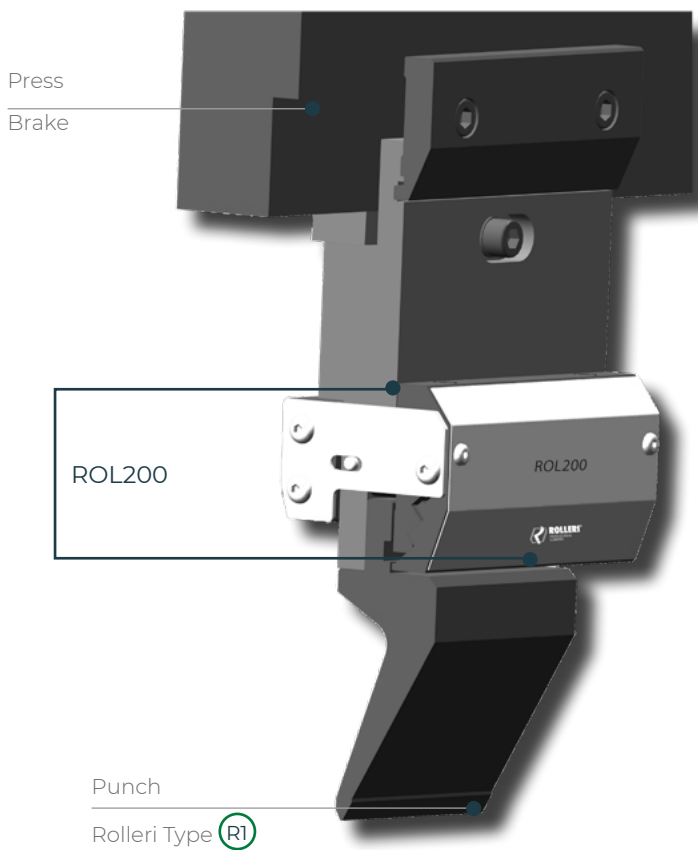

The new patent pending ROL200 system is compatible with all press brakes with Promecam-Amada type tang and it's very easy to use. This innovative fast clamping system can satisfy any needs as it can be mounted on new press brakes as well as on old retrofitted press brakes. Its installation is very quick and easy as the system is mounted on Rolleri standard intermediates.

- ▶ Fast vertical tool change for all Rolleri R1 type punches
- ▶ Can be used without modifying Rolleri R1 type punches
- ▶ Safe and fast tool change
- ▶ Substantial improvement in time consumption and related costs
- ▶ Secure against tool falling down
- ▶ Available in manual, pneumatic and hydraulic models
- ▶ Easy to mount on your press brake. Modification of the press brake is not necessary.

Vertical Tool change	●
Horizontal tool change	
Automatic tool alignment	●
R1 Tools modifications required	
Antifall system	●
Intermediate included	●
Pneumatic version	●
Hydraulic version	●
Manual version	●

ROL200 reduces press brake setup time and therefore it represents the best choice for users that frequently change punches on their press brake.





## LOCK

## UNLOCK



Insert the punch vertically



Pull the punch tip and when it's seated, pull it gently again until it reaches its working position



Pull the punch



Push the punch against the intermediate by keeping it up



Rotate the punch by pushing the punch tip

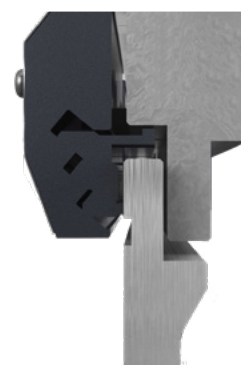

R1

# ROL200 - Single clamp

## ROL200 HYD

Hydraulic version

Bar 80



Length 150 mm

Intermediates	Comp.
Without intermediate	
INT100 FISSO	
INT120 FISSO	
INT150 FISSO	
INT120-40 FISSO	
INT100	
INT120	●
INT150	●
INT120-40	●
INT132-40	●
INT150-40	
INT120 HD	●
INT150 HD	
INT120-40 HD	●
INT150-40 HD	

### HPU-E/80

- ▶ To be connected to CNC for open-close function
- ▶ Gives electric signal to CNC in case of lowering pressure, setting press brake in Alarm stop
- ▶ Works on 220-380 volt
- ▶ Max pressure 80 bar
- ▶ 15 lit oil pump

## ROL200 PN

Pneumatic version

Bar 12



Length 150 mm

Intermediates	Comp.
Without intermediate	
INT100 FISSO	●
INT120 FISSO	●
INT150 FISSO	●
INT120-40 FISSO	●
INT100	
INT120	●
INT150	●
INT120-40	●
INT132-40	●
INT150-40	●
INT120 HD	●
INT150 HD	
INT120-40 HD	●
INT150-40 HD	

### ROL1 PDU MOLT

- ▶ Controls air pressure at entrance & at end of line of circuit
- ▶ Multiplies air from compressor to ensure best clamp closure
- ▶ Gives electric signal to CNC in case of lowering pressure, setting press brake in Alarm stop
- ▶ All intermediates are connected to each other through pneumatic pipes and work with air at 12 bar to guarantee high clamping force

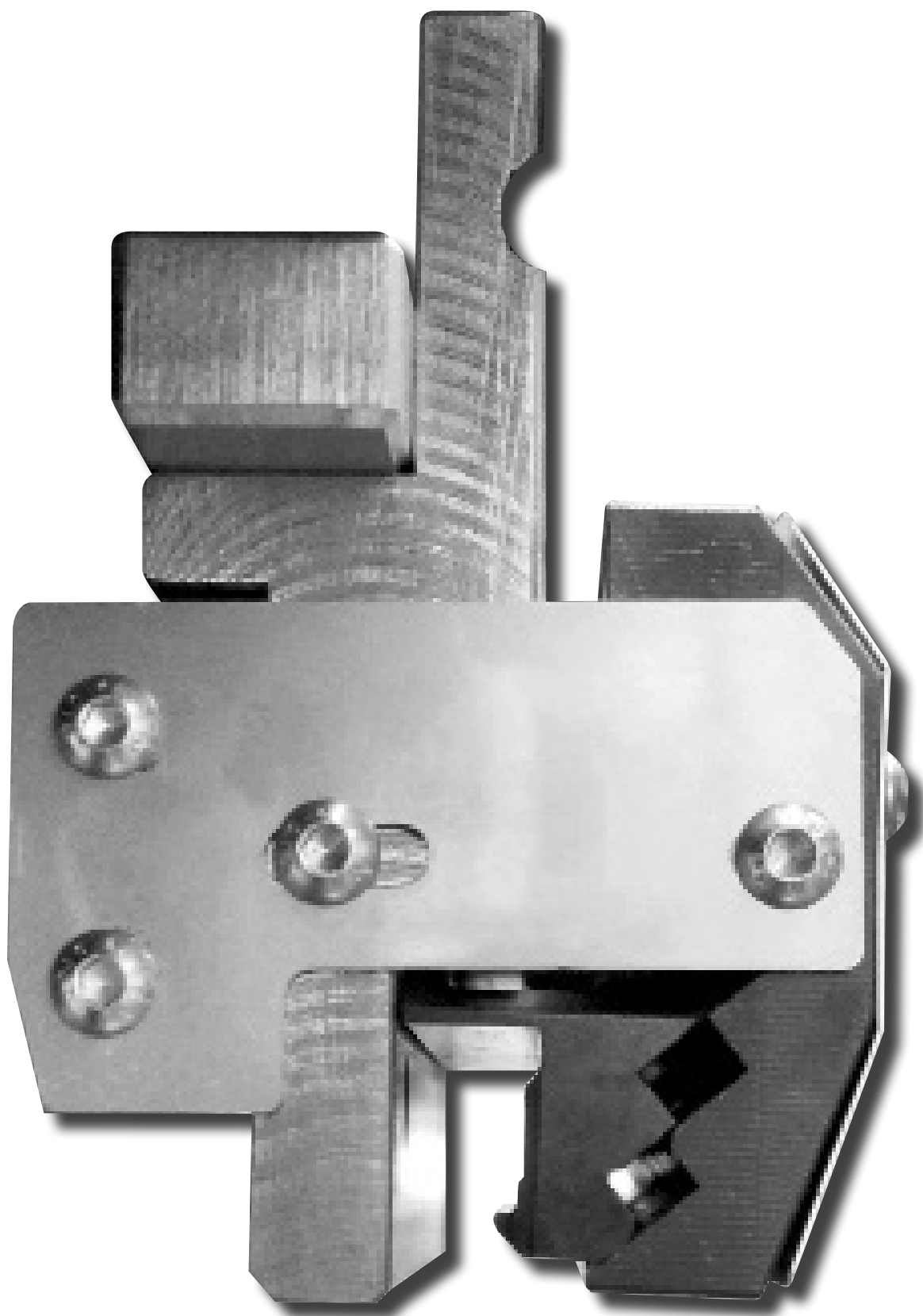

R1

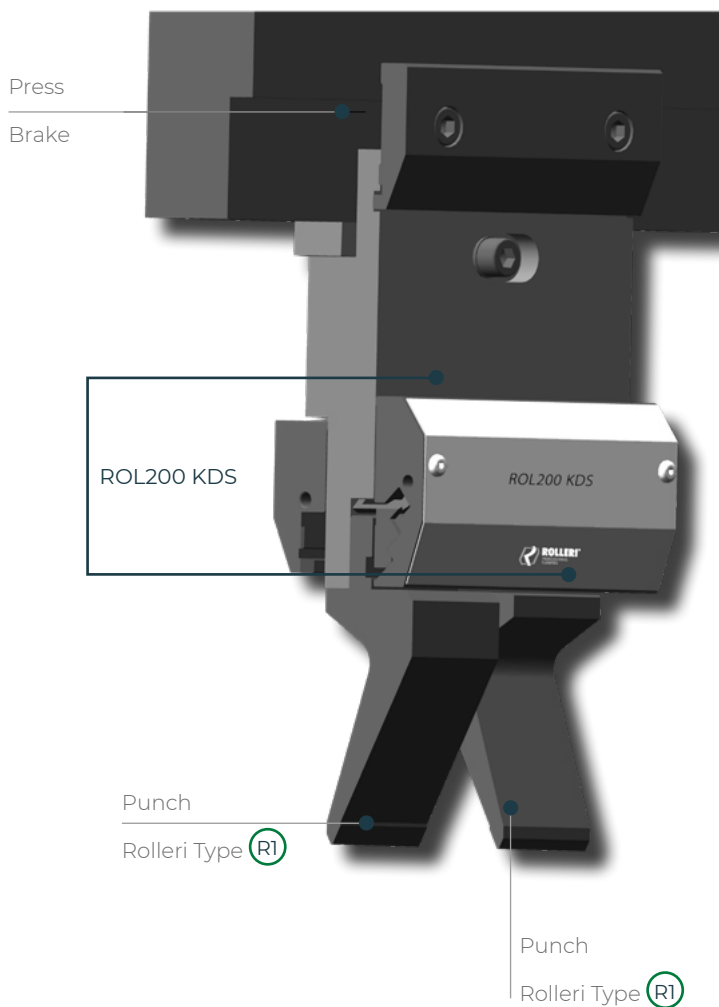

The new patent pending ROL200 KDS system is compatible with all press brakes with Promecam-Amada type tang and it's very easy to use. This innovative fast clamping system can satisfy any needs as it can be mounted on new press brakes as well as on old retrofitted press brakes.

Its installation is very quick and easy as the system is mounted on Rolleri standard intermediates.

- ▶ Safe and fast tool change
- ▶ Can be used without modifying Rolleri R1 type punches
- ▶ Front clamp - vertical tool change
- ▶ Rear clamp - horizontal tool change
- ▶ Available in manual, pneumatic and hydraulic models



Vertical Tool change	● Front
Horizontal tool change	● Rear
Automatic tool alignment	●
R1 Tools modifications required	
Antifall system	●
Intermediate included	●
Pneumatic version	●
Hydraulic version	●
Manual version	●

Our new ROL200 KDS combines practicality, reliability and security of Rol200 with the versatility of the back clamp: thanks to this, the system guarantees the maximum flexibility in terms of use



## LOCK



Insert the punch vertically



Pull the punch tip and when it's seated, pull it gently again until it reaches its working position

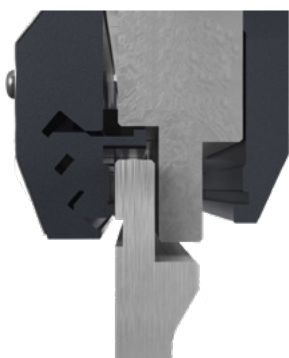

## UNLOCK



Pull the punch

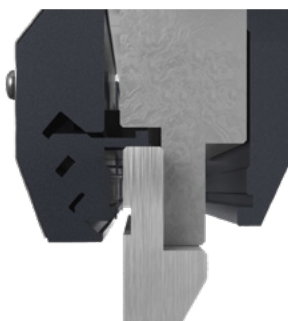

Push the punch against the intermediate by keeping it up



Rotate the punch by pushing the punch tip

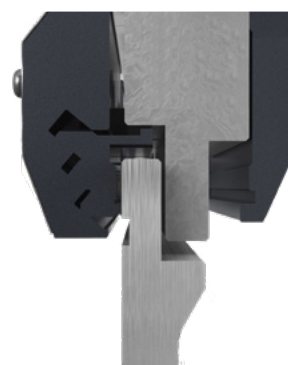

R1

# ROL200 KDS - Double clamp

## ROL200 MAN

Manual version



Length 150 mm

Intermediates	Comp.
Without intermediate	
INT100 FISSO	●
INT120 FISSO	
INT150 FISSO	
INT120-40 FISSO	
INT100	●
INT120	●
INT150	●
INT120-40	●
INT132-40	●
INT150-40	●
INT120 HD	●
INT150 HD	●
INT120-40 HD	●
INT150-40 HD	●

ROL200 manual is very simple to use thanks to a central screw with controlled stroke, which ensures quick and safe tool clamping.

The intermediate doesn't need any connection to external devices (opposite to pneumatic or hydraulic systems), which makes its installation very fast like any other Roller intermediate.

ROL200 manual is available with back clamp to mount punches on the back of the intermediate to bend complicated profiles.

## ROL200 KDS HYD

Hydraulic version

Bar 80



Length 150 mm

Intermediates	Comp.
Without intermediate	
INT100 FISSO	●
INT120 FISSO	●
INT150 FISSO	●
INT120-40 FISSO	●
INT100	
INT120	●
INT150	●
INT120-40	●
INT132-40	●
INT150-40	●
INT120 HD	
INT150 HD	
INT120-40 HD	
INT150-40 HD	

### HPU-E/80

- ▶ To be connected to CNC for open-close function
- ▶ Gives electric signal to CNC in case of lowering pressure, setting press brake in Alarm stop
- ▶ Works on 220-380 volt
- ▶ Max pressure 80 bar
- ▶ 15 lit oil pump



## ROL200 KDS PN

Pneumatic version

Bar 12



Length 150 mm

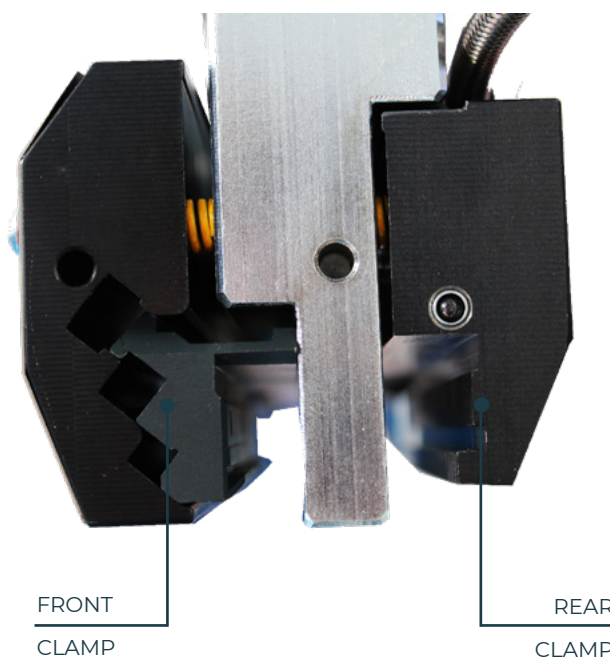

FRONT  
CLAMP

REAR  
CLAMP

R1

Intermediates	Comp.
Without intermediate	
INT100 FISSO	●
INT120 FISSO	●
INT150 FISSO	●
INT120-40 FISSO	●
INT100	
INT120	●
INT150	●
INT120-40	●
INT132-40	●
INT150-40	●
INT120 HD	
INT150 HD	
INT120-40 HD	
INT150-40 HD	



ROL200 pneumatic dramatically reduces press brake setup time and therefore it represents the best choice for users that frequently change punches on their press brake. All intermediates are connected to each other through pneumatic pipes and work with air at 12 bar to guarantee high clamping force.

### ROL1 PDU MOLT

- ▶ Controls air pressure at entrance & at end of line of circuit
- ▶ Multiplies air from compressor to ensure best clamp closure
- ▶ Gives electric signal to CNC in case of lowering pressure, setting press brake in Alarm stop
- ▶ All intermediates are connected to each other through pneumatic pipes and work with air at 12 bar to guarantee high clamping force

# ROL200

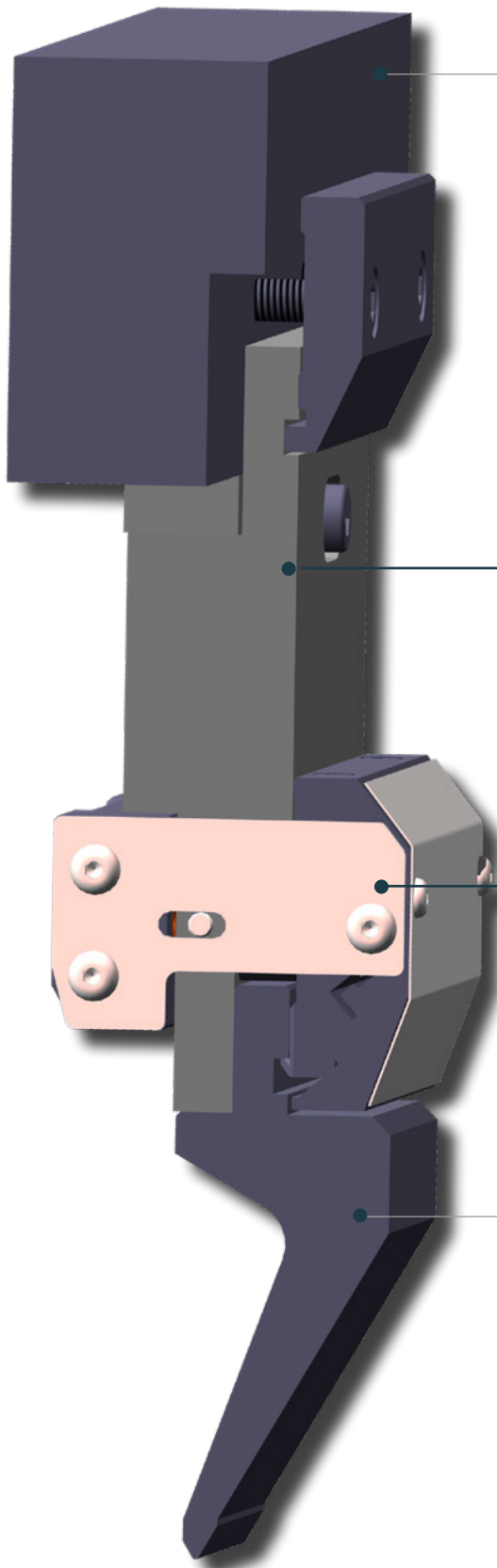

Press brake

INTERMEDIATE

EX. H.150 MM

PAGE 22 INTERMEDIATES

AVAILABLE

ROL200

FRONT CLAMP

Punch - Type RT



# ROL200 KDS

Press brake

INTERMEDIATE

EX. H.100 MM

PAGES 26 - 27 INTERMEDIATES

AVAILABLE

FRONT CLAMP

ROL200

KDS

REAR CLAMP

Punch - Type **R1**

Punch - Type **R1**

**R1**

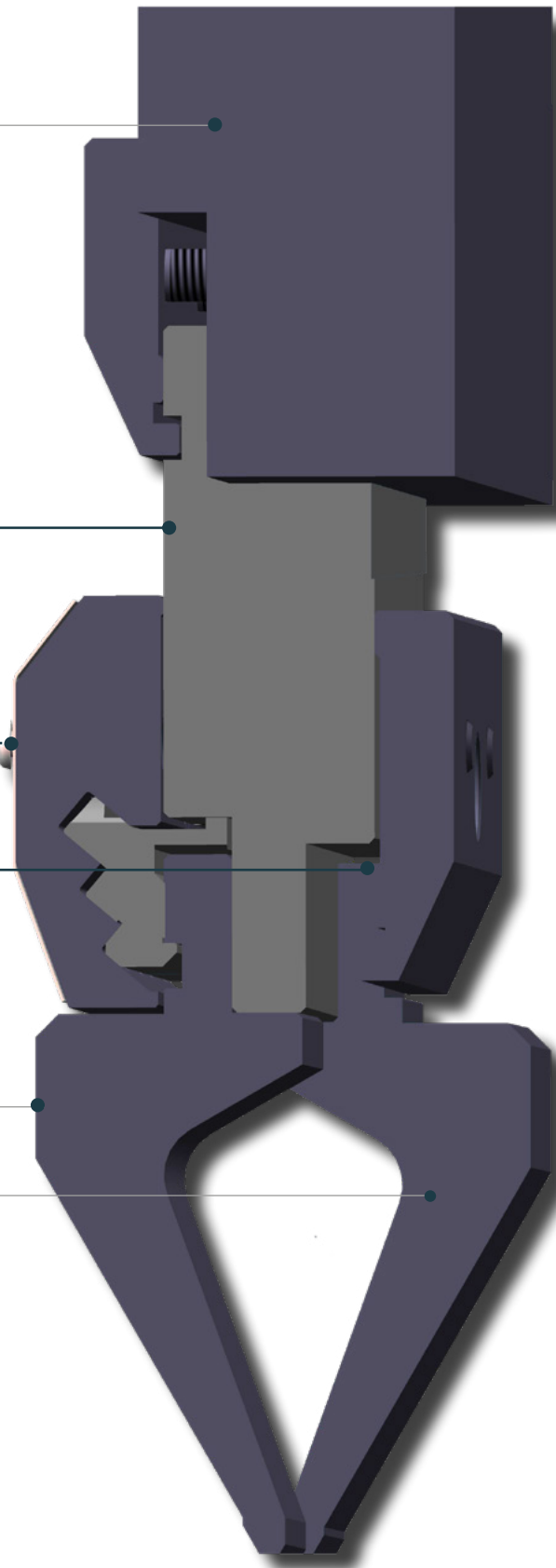

Press Brake

ROL4

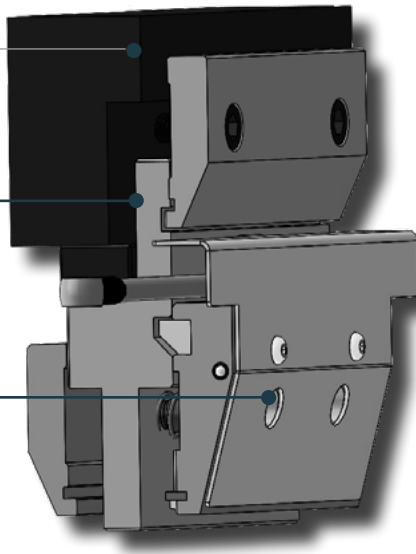

- ▶ Horizontal tool exchange
- ▶ Integrated KDS-System
- ▶ For Standard-Punches Rolleri Type R1. There are no modifications necessary!
- ▶ Manual Back Clamp standard on both versions
- ▶ Automatic tool alignment

INTERMEDIATE

CROWNING  
WEDGE

CLAMP

Punch

Rolleri Type **R1**

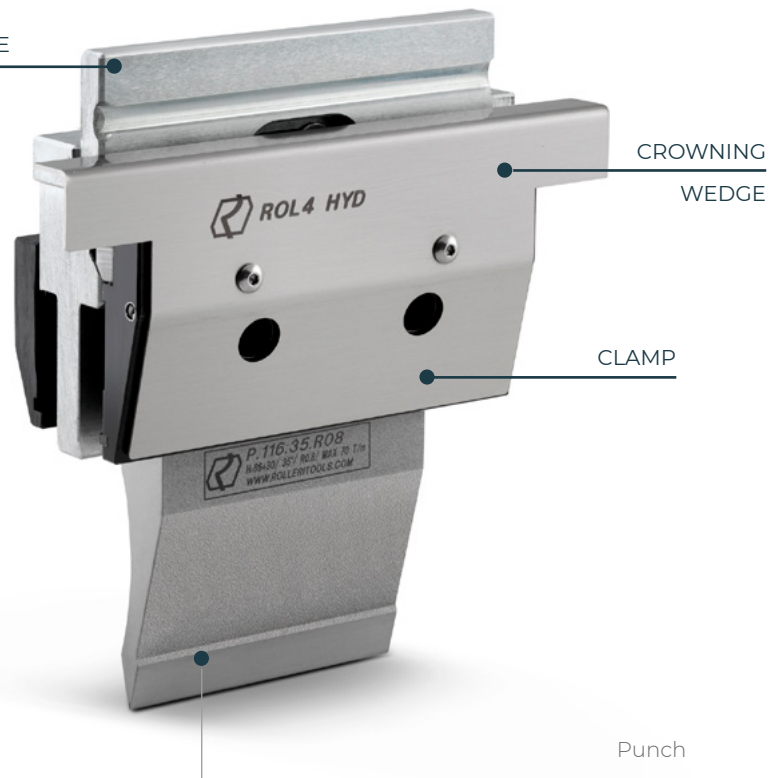

Vertical Tool change	
Horizontal tool change	●
Automatic tool alignment	●
R1 Tools modifications required	
Antifall system	●
Intermediate included	●
Pneumatic version	
Hydraulic version	●
Manual version	●



INTERMEDIATE

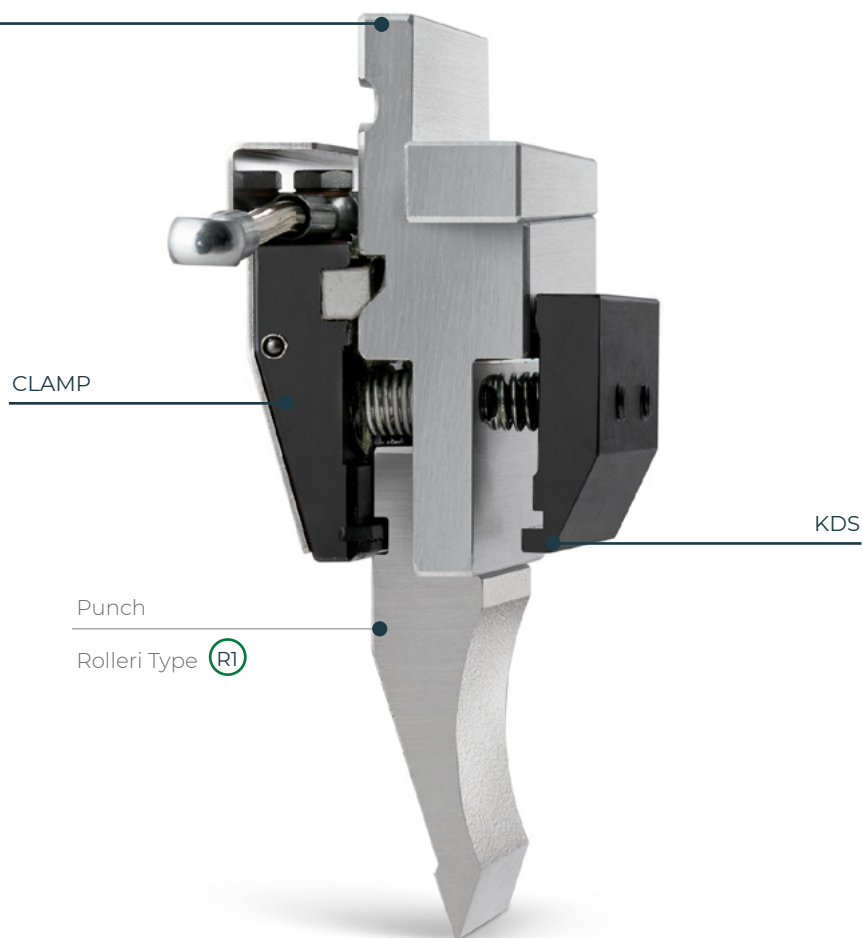

R1

# ROL4

## ROL4 MAN

Manual version

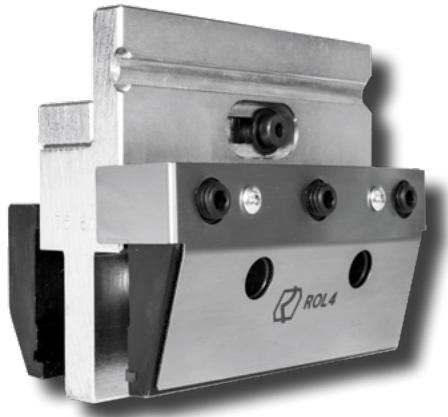

Length 150 mm

Intermediates	Comp.
Without intermediate	
INT100 FISSO	●
INT120 FISSO	●
INT150 FISSO	●
INT120-40 FISSO	●
INT100	●
INT120	●
INT150	●
INT120-40	●
INT132-40	●
INT150-40	●
INT120 HD	●
INT150 HD	●
INT120-40 HD	●
INT150-40 HD	●

## ROL4 HYD

Hydraulic version

Bar 160



Length 150 mm

Intermediates	Comp.
Without intermediate	
INT100 FISSO	●
INT120 FISSO	●
INT150 FISSO	●
INT120-40 FISSO	●
INT100	●
INT120	●
INT150	●
INT120-40	
INT132-40	●
INT150-40	●
INT120 HD	●
INT150 HD	●
INT120-40 HD	●
INT150-40 HD	●

### HPU-E

- ▶ To be connected to CNC for open-close function
- ▶ Gives electric signal to CNC in case of lowering pressure, setting press brake in Alarm stop
- ▶ Works on 220-380 volt
- ▶ Max pressure 160 bar
- ▶ 15 lit oil pump

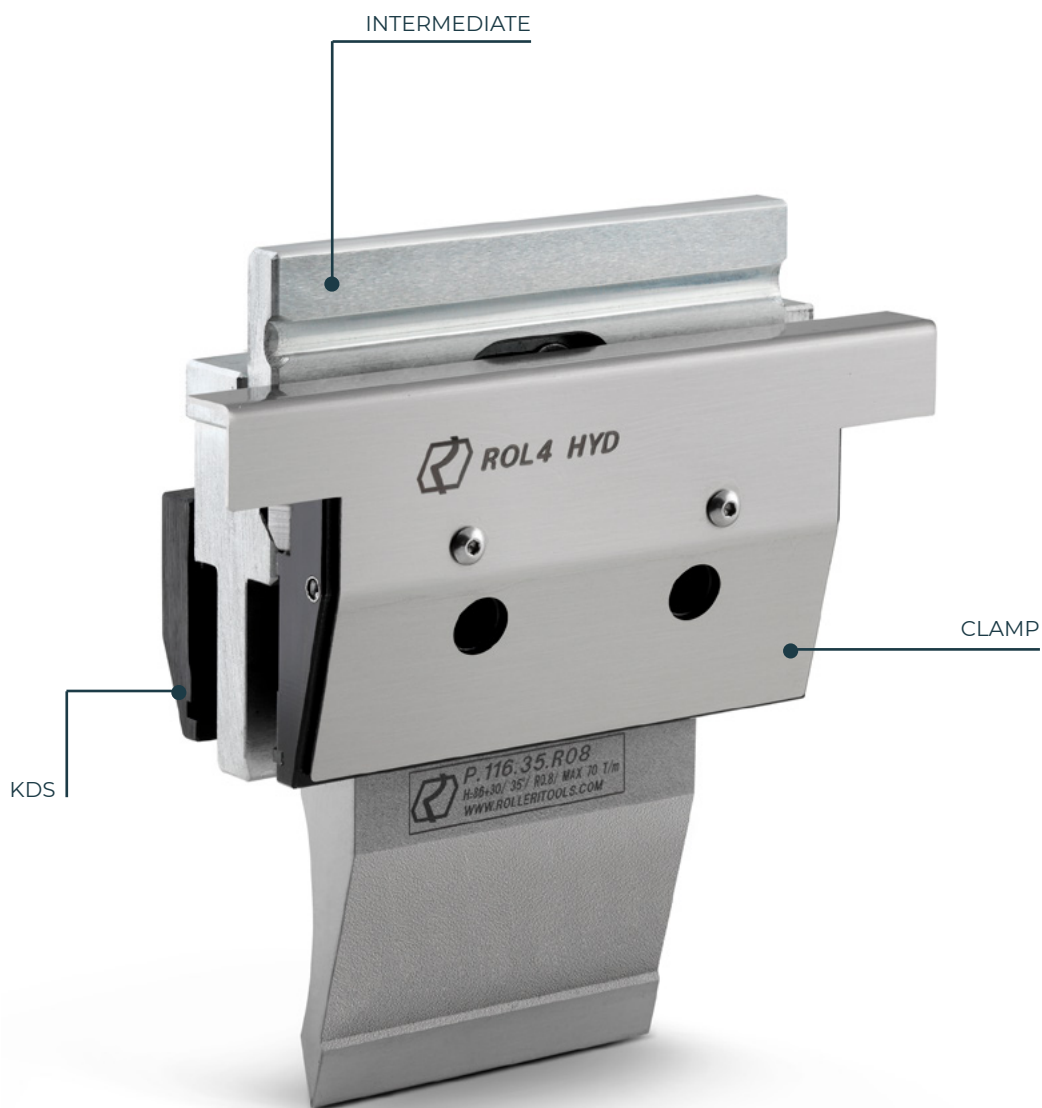

R1

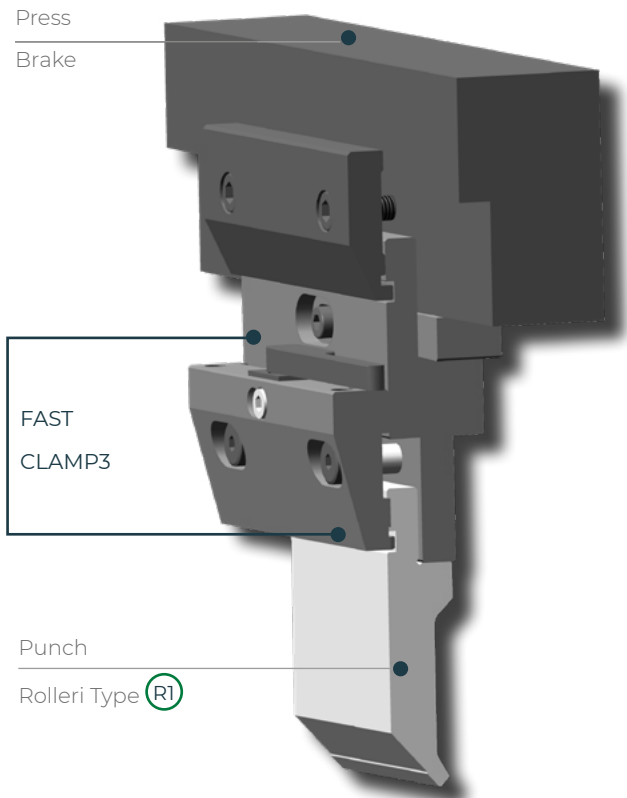

- ▶ Thanks to its curved construction, ROLICLAMP3 guarantees perfect clamping and alignment of small segments
- ▶ Ergonomic lever on the clamp to open and close easily
- ▶ Hardened plate mounted between clamp and intermediate to protect them against wear
- ▶ Fast mounting system through springs and buttonholes
- ▶ Made of C45 nitrated
- ▶ Long life cycle

Vertical Tool change	
Horizontal tool change	●
Automatic tool alignment	
R1 Tools modifications required	
Antifall system	●
Intermediate included	
Pneumatic version	
Hydraulic version	
Manual version	●

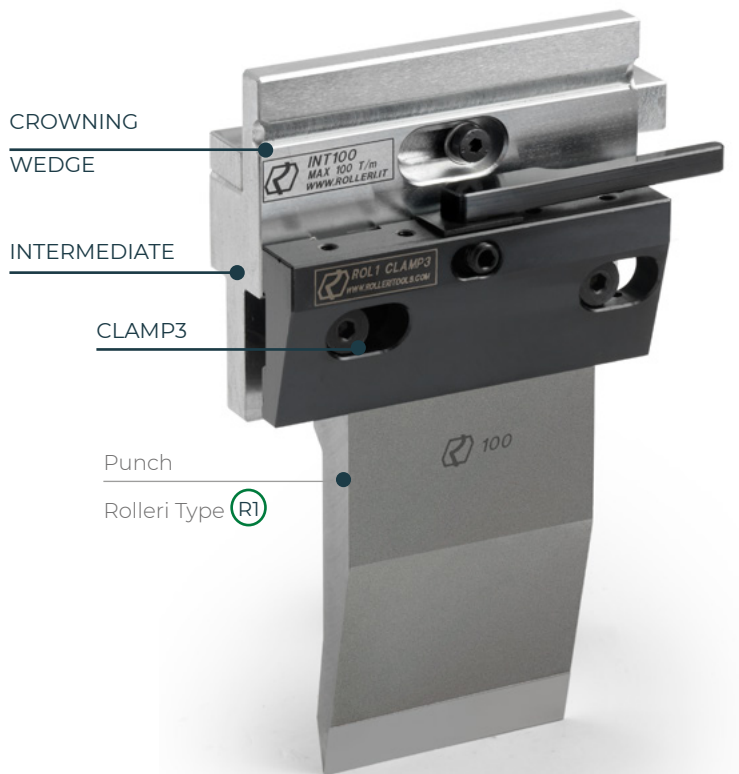

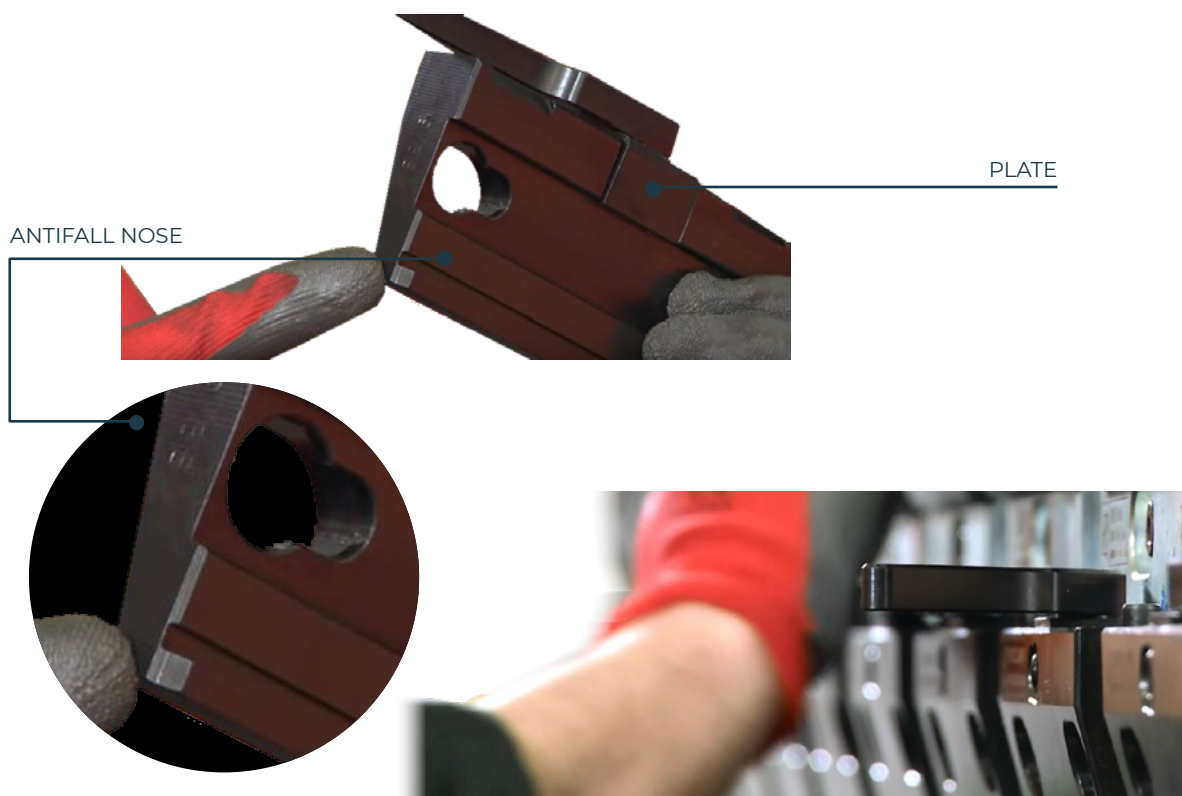

R1

Fe37: 370-470 N/mm<sup>2</sup>

KDS

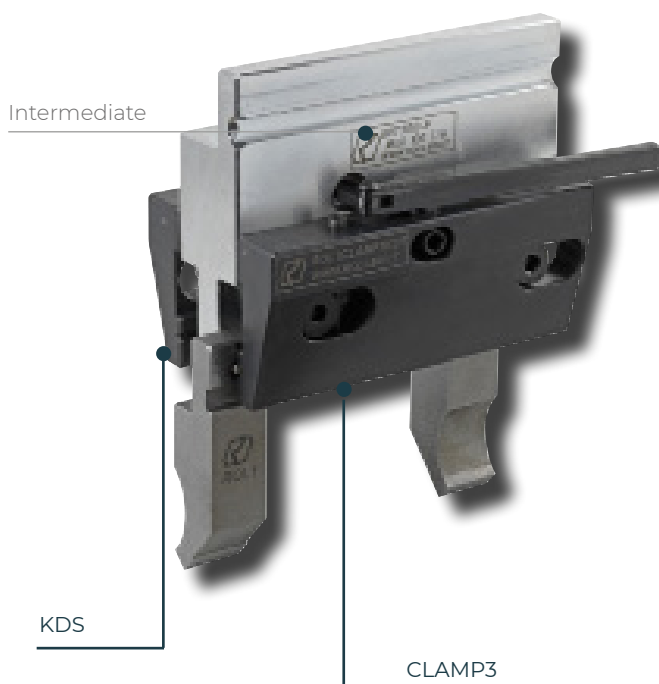

Vertical Tool change	
Horizontal tool change	●
R1 Tools modifications required	
Antifall system	●
Intermediate included	●
Pneumatic version	
Hydraulic version	
Manual version	●

# FAST CLAMP3

## ROLI CLAMP3 MAN



Length 150 mm

Intermediates	Comp.
Without intermediate	●
INT100 FISSO	●
INT120 FISSO	●
INT150 FISSO	●
INT120-40 FISSO	●
INT100	●
INT120	●
INT150	●
INT120-40	●
INT132-40	●
INT150-40	●
INT120 HD	●
INT150 HD	●
INT120-40 HD	●
INT150-40 HD	●

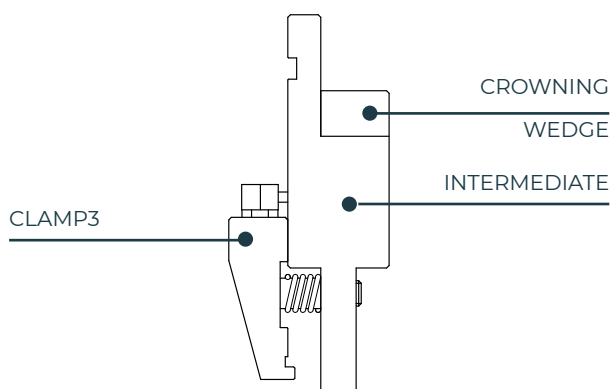
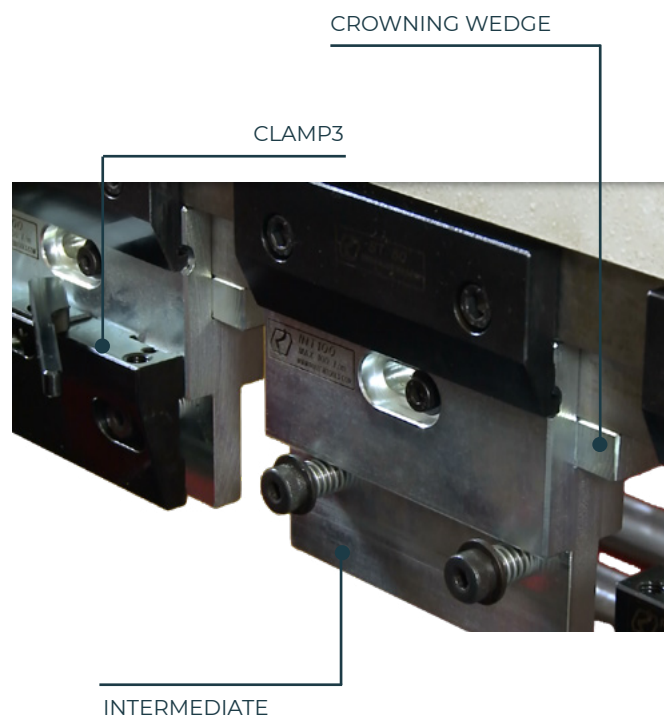

### What is **FAST CLAMP3**?

FAST CLAMP3 is every manual clamping composed of:

- ▶ One intermediate (pages 16 - 17)
- ▶ One front CLAMP 3





**ROLI CLAMP3 KDS MAN**

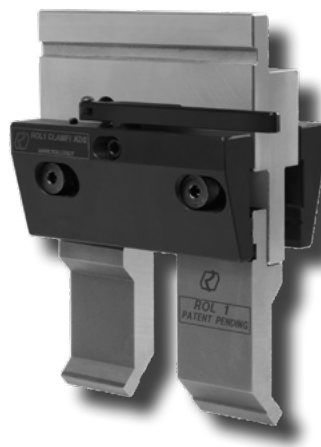

Length | 150 mm

Intermediates	Comp.
Without intermediate	●
INT100 FISSO	●
INT120 FISSO	●
INT150 FISSO	●
INT120-40 FISSO	●
INT100	●
INT120	●
INT150	●
INT120-40	●
INT132-40	●
INT150-40	●
INT120 HD	
INT150 HD	
INT120-40 HD	
INT150-40 HD	

What is **DOUBLE FAST CLAMP3**?

DOUBLE FAST CLAMP3 is every manual clamping composed of:

- ▶ One intermediate (pages 16 - 17)
- ▶ One front CLAMP3
- ▶ One rear clamp KDS (page 19)

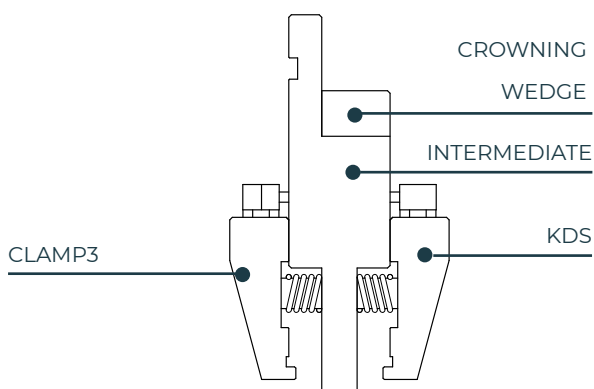

R1

Press Brake

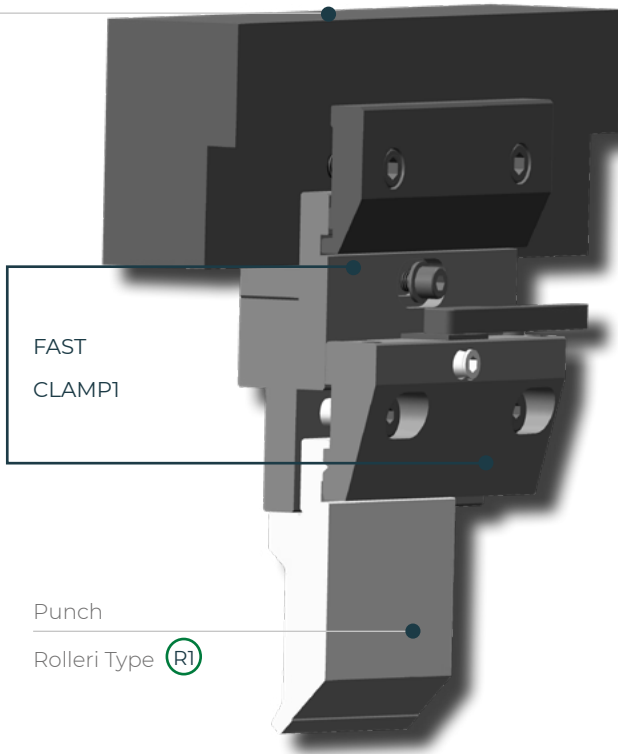

ROLI can be used on all press brakes with Rolleri R1 type intermediates with standard tang.

In order to use the ROLI System, punches are modified and equipped with spring-loaded ball bearings.

- ▶ Vertical clamping of tools is possible thanks to a row of spring-loaded ball bearings which are also used as antifall system to prevent punches from falling down
- ▶ A complete mechanical and efficient fast clamping system for press brakes
- ▶ Productivity and versatility of press brakes is substantially increased
- ▶ Significant reduction in the set-up times when changing tools
- ▶ Automatic tool alignment

ROLI system has been designed for press brakes that mount intermediates max. at 70mm distance to each other. In case the distance between intermediates is bigger, make sure that a minimum quantity of ball bearings is in the clamp. Such quantity depends on the type of the tool and its length.

Vertical Tool change	●
Horizontal tool change	
Automatic tool alignment	●
R1 Tools modifications required	●
Antifall system	●
Intermediate included	●
Pneumatic version	
Hydraulic version	
Manual version	●

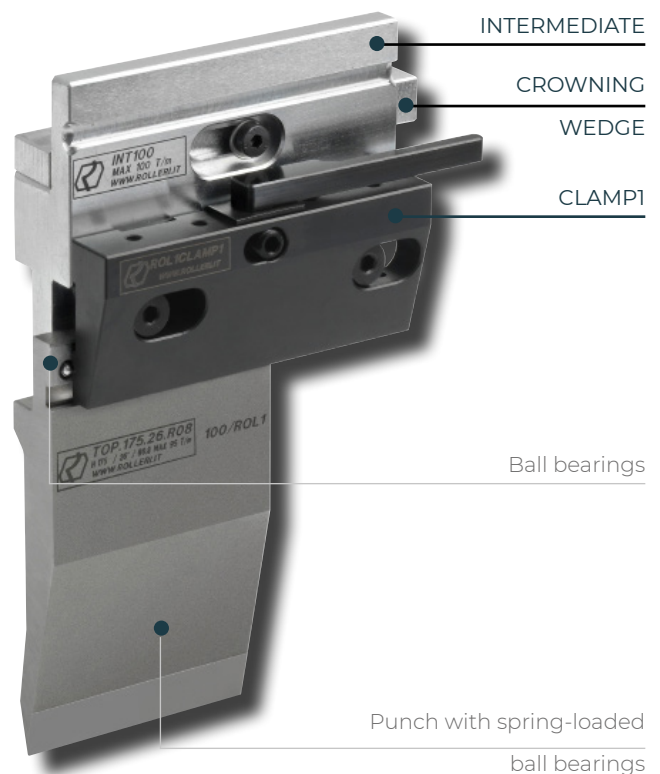



INTERMEDIATE  
INT100  
CLAMP  
ROLI CLAMP1



**MOUNTING EXAMPLE**

Punch  
Rolleri Type **R1**  
with spring-loaded balls



**R1**

Fe37: 370-470 N/mm<sup>2</sup>

**KDS**

INTERMEDIATE

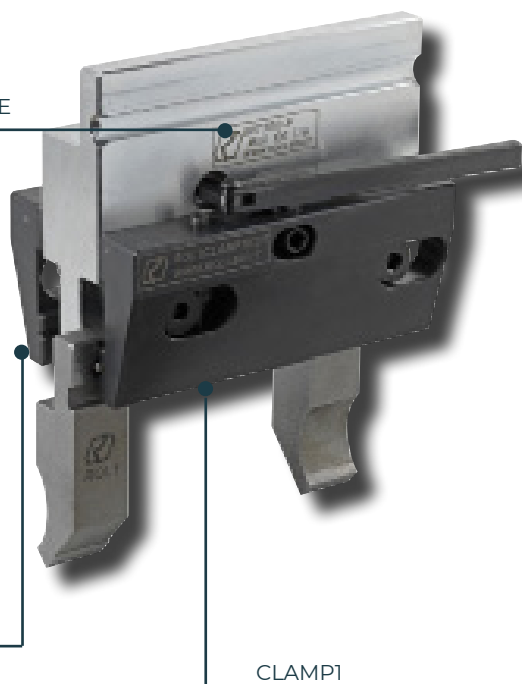

Vertical Tool change	●
Horizontal tool change	
R1 Tools modifications required	●
Antifall system	●
Intermediate included	
Pneumatic version	
Hydraulic version	
Manual version	●

# FAST CLAMP1

## ROL1 CLAMP1 MAN



Length 150 mm

Intermediates	Comp.
Without intermediate	●
INT100 FISSO	●
INT120 FISSO	●
INT150 FISSO	●
INT120-40 FISSO	●
INT100	●
INT120	●
INT150	●
INT120-40	●
INT132-40	●
INT150-40	●
INT120 HD	●
INT150 HD	●
INT120-40 HD	●
INT150-40 HD	●

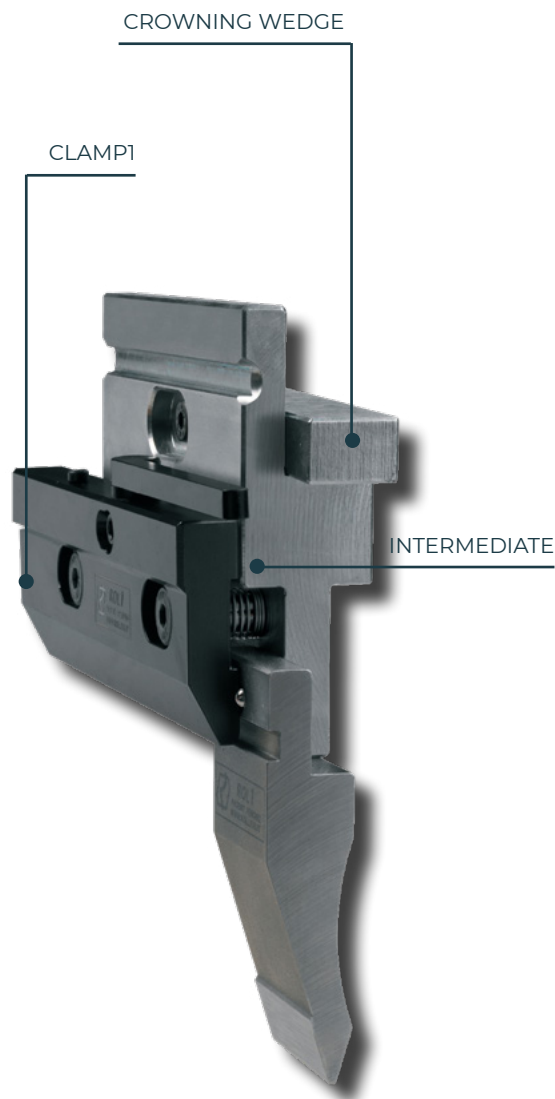
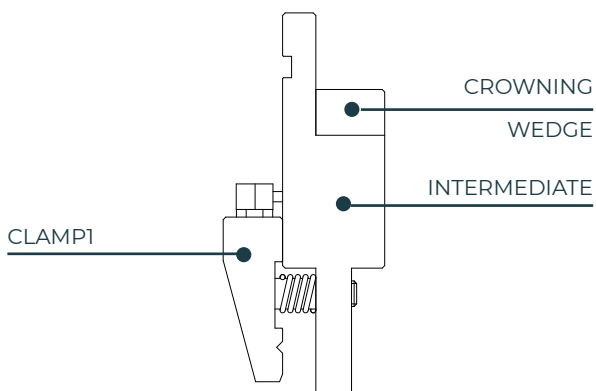

### What is **FAST CLAMP1**?

FAST CLAMP1 is every manual clamping composed of:

- ▶ One intermediate (pages 16 - 17)
- ▶ One front CLAMP1



**ROL1 CLAMP1 KDS MAN**



**R1**

Length	150 mm
--------	--------

Intermediates	Comp.
Without intermediate	●
INT100 FISSO	●
INT120 FISSO	●
INT150 FISSO	●
INT120-40 FISSO	●
INT100	●
INT120	●
INT150	●
INT120-40	●
INT132-40	●
INT150-40	●
INT120 HD	
INT150 HD	
INT120-40 HD	
INT150-40 HD	

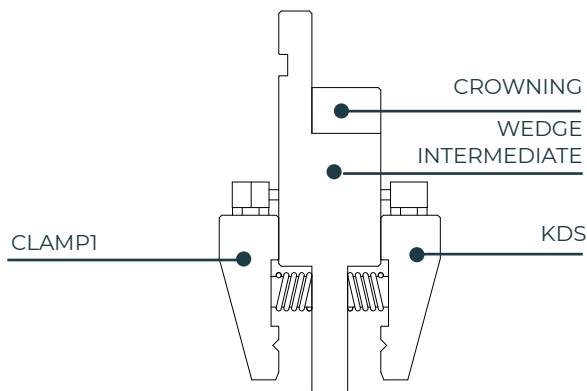

**What is DOUBLE FAST CLAMP1?**

DOUBLE FAST CLAMP1 is every manual clamping composed of:

- ▶ One intermediate (pages 16 - 17)
- ▶ One front CLAMP1
- ▶ One rear clamp KDS (page 19)

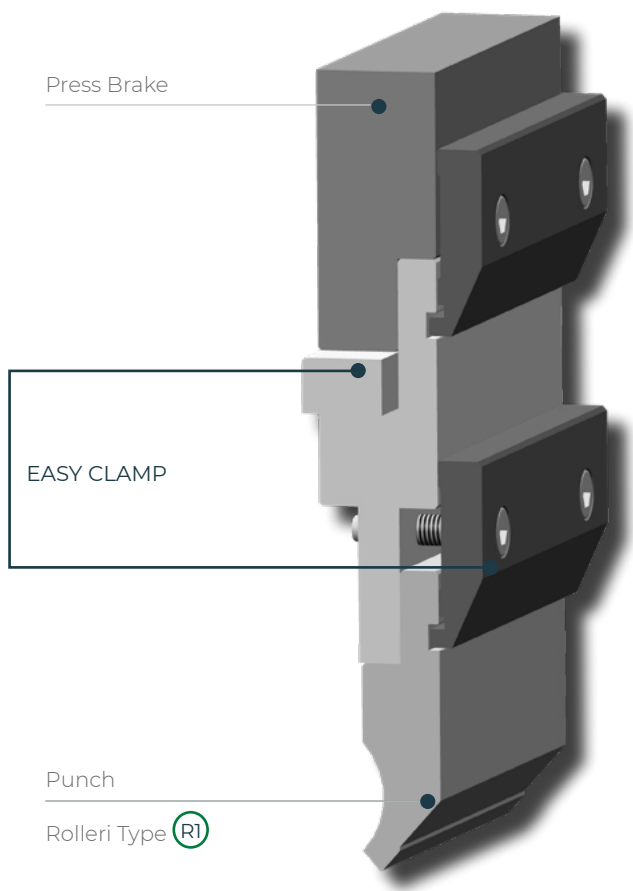

- ▶ R1 Tools type
- ▶ Available with 7 or 20 mm distance from tag
- ▶ Closing by screw with ST60 plate
- ▶ Made in C45 Steel

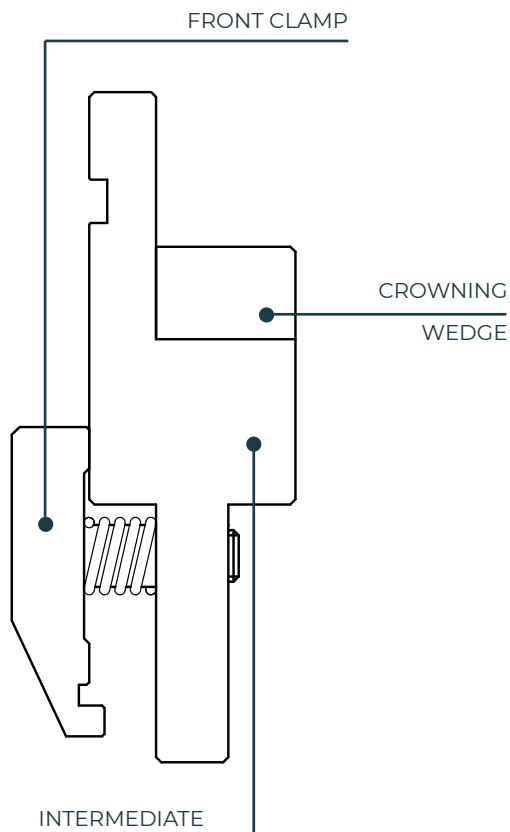

Vertical Tool change	
Horizontal tool change	●
Automatic tool alignment	
R1 Tools modifications required	
Antifall system	●
Intermediate included	●
Pneumatic version	
Hydraulic version	
Manual version	●

What is **EASY CLAMP**?

EASY CLAMP is every manual clamping composed of:

- One intermediate (pages 16 - 17)
- One front clamp (pages 18 - 19)



# CLAMPS

## Front clamp

- ▶ Clamping Systems enable fast horizontal tool change.
- ▶ Plastic Pressure Strip improves clamping especially with short tool segments.

Needed clamps	Length of press brake
4 pieces	835 mm
6 pieces	1250 mm
11 pieces	2100 mm
14 pieces	2600 mm
16 pieces	3100 mm
21 pieces	4100 mm

Fe37: 370-470 N/mm<sup>2</sup>

### ST60 / ST60R / STG60

ST60	150 mm	0.80 kg
ST60R	150 mm	0.85 kg
STG60	150 mm	0.80 kg

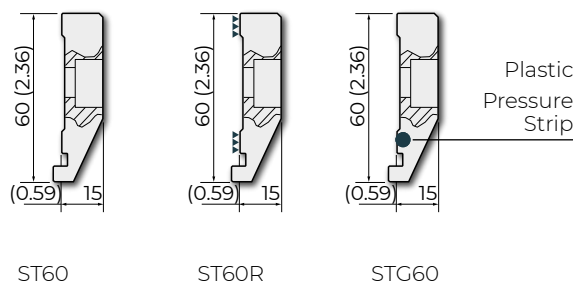
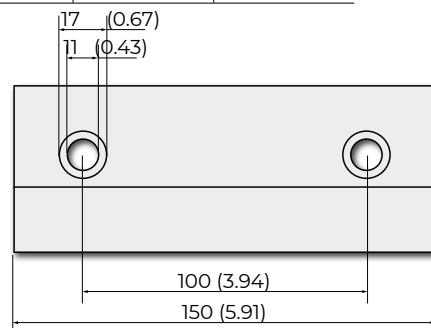

R1

Fe37: 370-470 N/mm<sup>2</sup>

### STL60 / STL60R / STLG60

STL60	150 mm	0.80 kg
STL60R	150 mm	0.85 kg
STLG60	150 mm	0.80 kg

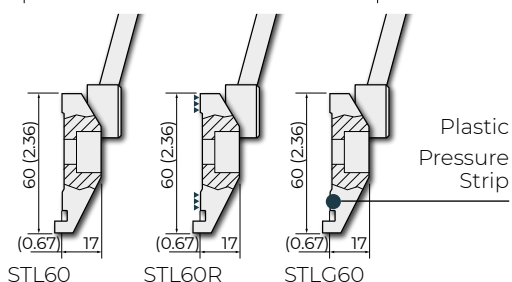
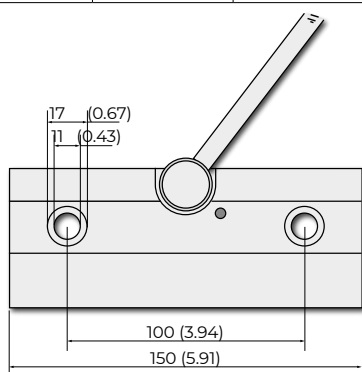

Fe37: 370-470 N/mm<sup>2</sup>

### STX60 / STX60R / STXG60

STX60	150 mm	0.85 kg
STX60R	150 mm	0.50 kg
STXG60	150 mm	1.00 kg

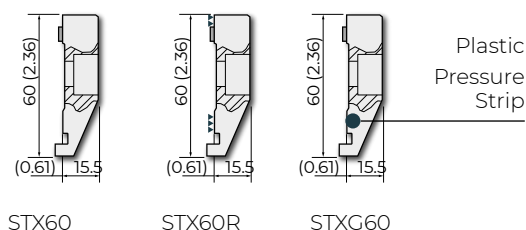
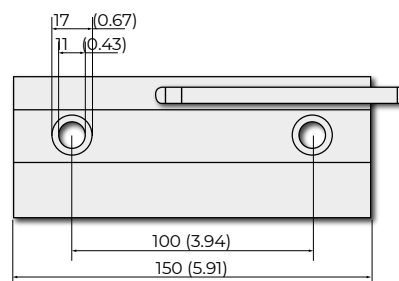

# EASY CLAMP

	ST60	ST60R	STG60	STL60	STL60R	STLG60	STX60	STX60R	STXG60
INT100 FISSO	●	●	●	●	●	●	●	●	●
INT100	●	●	●	●	●	●	●	●	●
INT120*	●	●	●	●	●	●	●	●	●
INT150*	●	●	●	●	●	●	●	●	●
INT120-40	●	●	●	●	●	●	●	●	●
INT132-40	●	●	●	●	●	●	●	●	●
INT150-40	●	●	●	●	●	●	●	●	●
INT120 HD	●	●	●	●	●	●	●	●	●
INT 150 HD	●	●	●	●	●	●	●	●	●
INT120-40 HD	●	●	●	●	●	●	●	●	●
INT150-40 HD	●	●	●	●	●	●	●	●	●

\* Available also version without crowning wedge



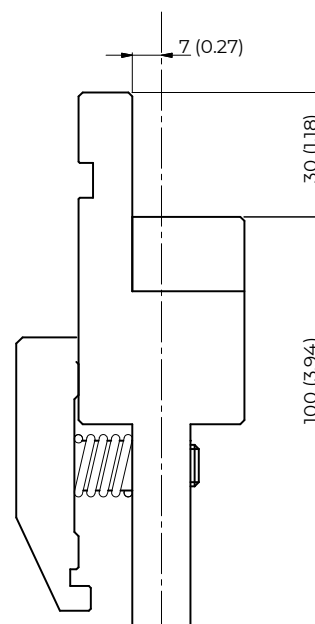
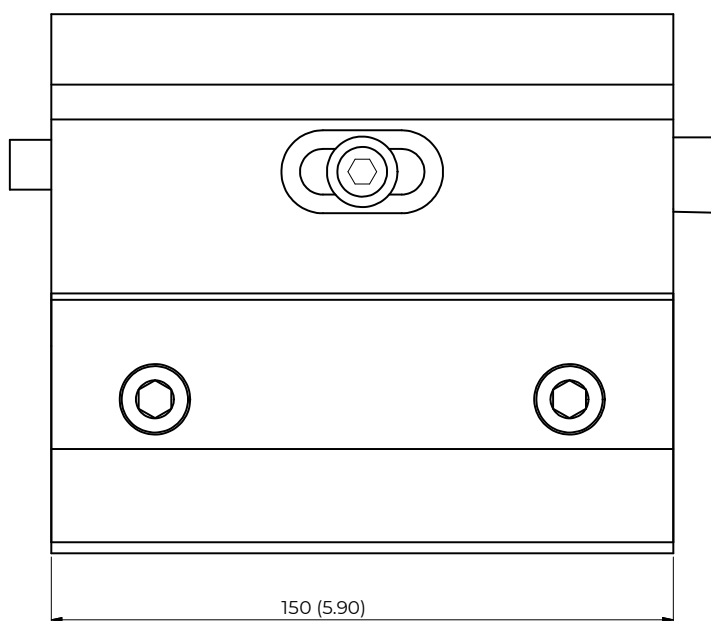
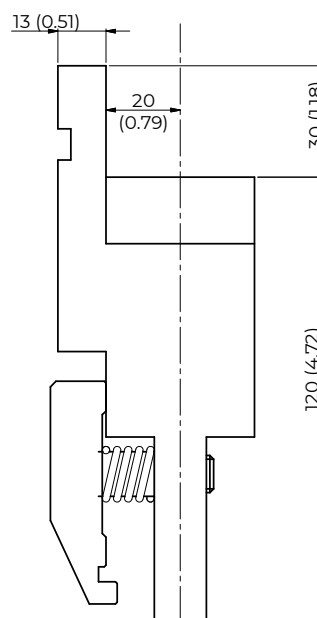
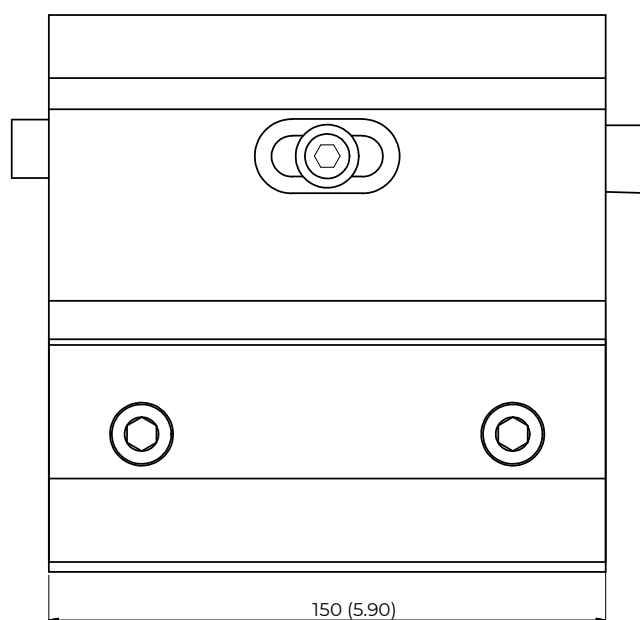

R1

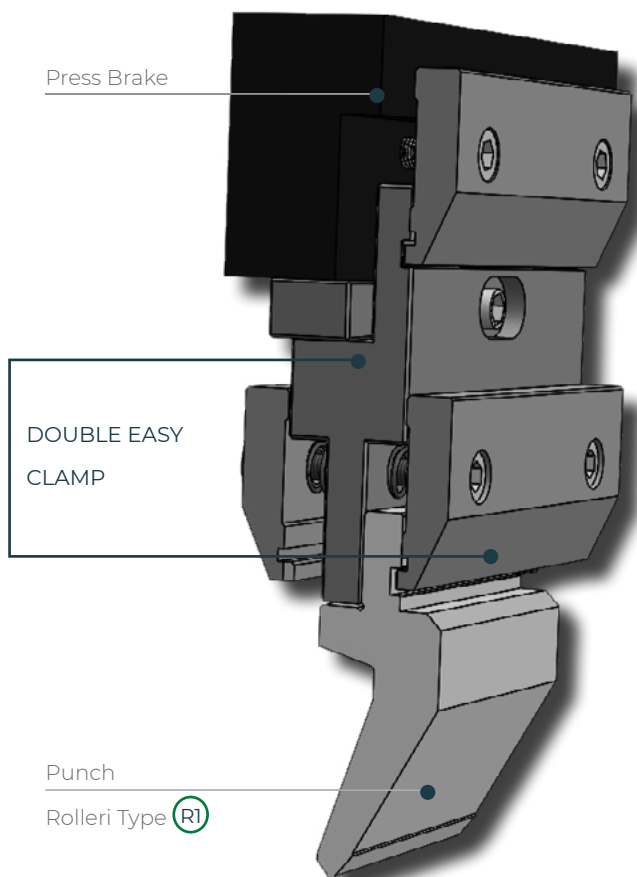

- ▶ R1 Tools type
- ▶ Available with 7 or 20 mm distance from tang
- ▶ Closing by screw with ST60 plate
- ▶ Made in C45 Steel

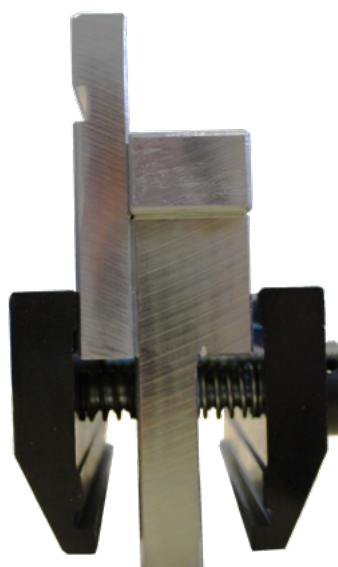

Vertical Tool change	
Horizontal tool change	●
Automatic tool alignment	
R1 Tools modifications required	
Antifall system	●
Intermediate included	●
Pneumatic version	
Hydraulic version	
Manual version	●

What is **DOUBLE EASY CLAMP**?

DOUBLE EASY CLAMP is every manual clamping composed of:

- ▶ One intermediate (pages 16 - 17)
- ▶ One front clamp (pages 42 - 43)
- ▶ One rear clamp KDS ( page 47)

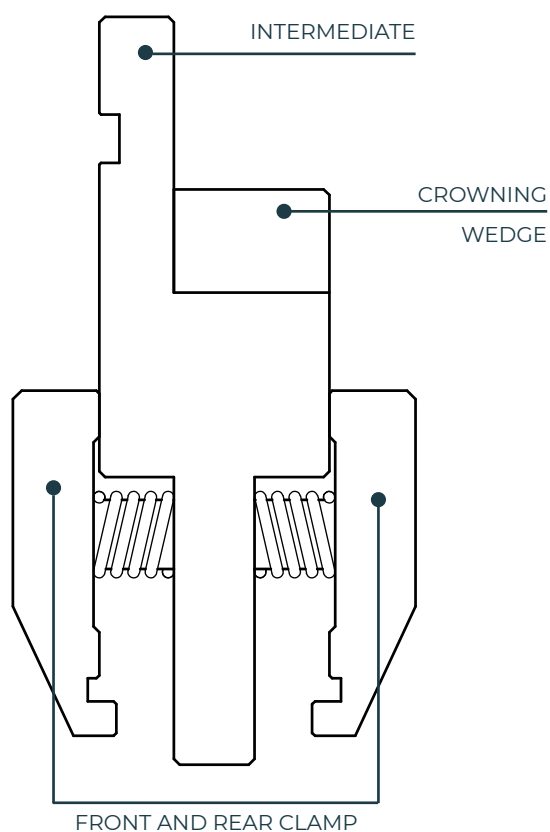

R1

Fe37: 370-470 N/mm<sup>2</sup>

### KDS

INTERMEDIATE

CROWNING WEDGE

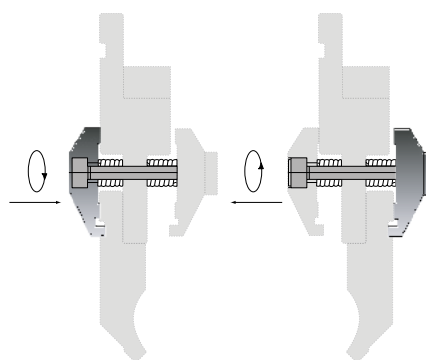
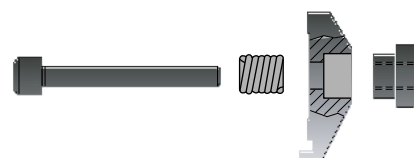
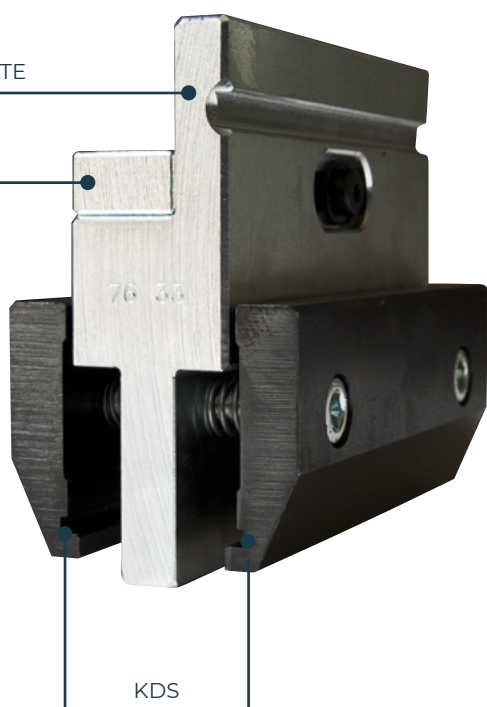

Clamp	●
Intermediates	

# DOUBLE EASY CLAMP

Intermediates available

INT100 FISSO

INT100

INT120\*

INT150\*

INT120-40

INT132-40

INT150-40

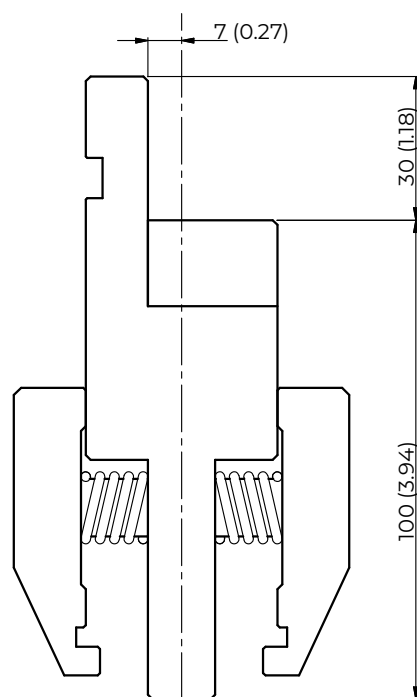
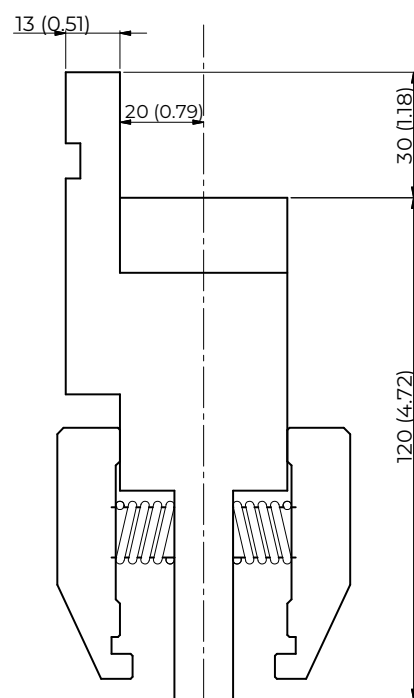

\* Available also version without crowning wedge



R1

# Clamps

- ▶ Lowerable clamping plate
- ▶ Significantly easier tool change, thanks to the possibility of removing the tool by sliding it out and not lifting it

Fe37: 370-470 N/mm<sup>2</sup>

**ST50-S**

0.70 kg

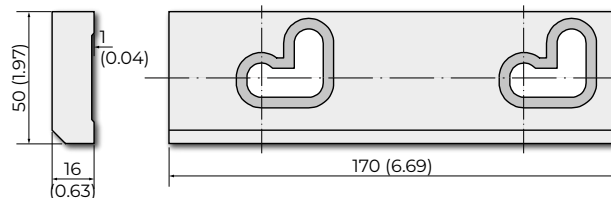

Dies

Type **(R1)**

CLAMPS  
STX50-S





R1



## ROL2

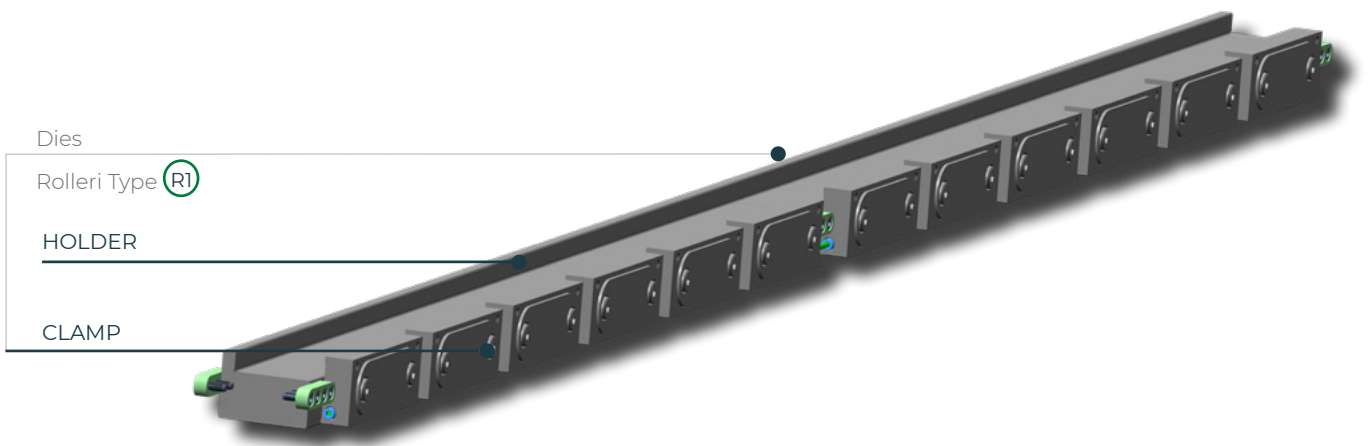

Example: ROL 2 PNUEMATIC



- ▶ Fast tool change
- ▶ Time-saving system
- ▶ Reduced production costs
- ▶ Significantly increased profitability
- ▶ Improved competitiveness

The ROL2 System is a system which is used to secure the die into place. Such system is available in manual, pneumatic and hydraulic version. The manual version is composed of a special clamp (known as ROL2 CLAMP1), which is operated with a central lever.

The ROL2 System has a built in spring mechanism which opens and closes the ROL2 CLAMP1 to clamp and release dies. A special rubber insert inside the clamp plates guarantees the best positioning for the tools. The press force of the clamp plates is evenly distributed along the complete length. Therefore short tools are also securely fastened.

Pneumatic version	●
Hydraulic version	●
Manual version	●

For example, in a 3 m press brake all dies are secured with 6 simple hand movements.

Rolleri new ROL2 pneumatic system is composed of pneumatic clamps L=150 mm which are activated by a pneumatic driving unit or by the CNC of the press brake. The new design has bigger clamping force and therefore it enables perfect clamping of small segments too.



### 60 mm wide press brake table

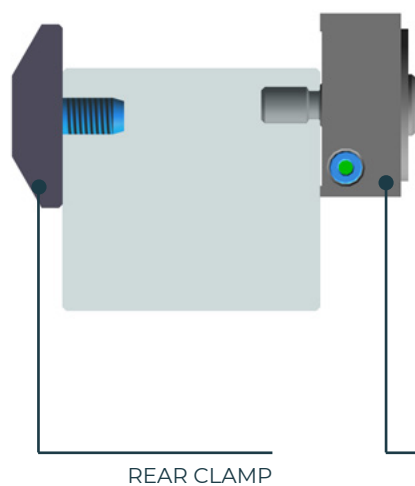

### 90 mm wide press brake table

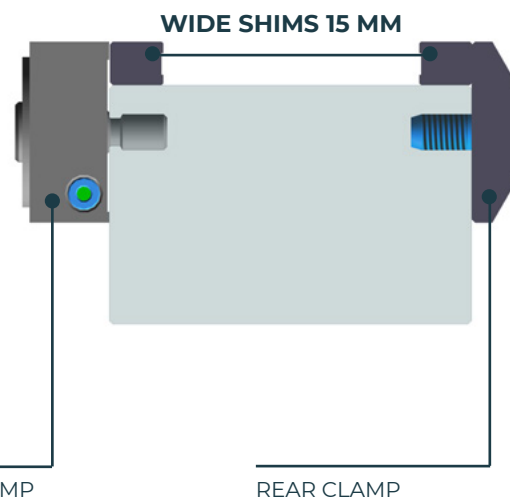

R1

Directly on a 60 mm wide press brake table \*

- Use of existing holes for the standard clamp plates (hole distance 100 mm)
- Alternatively modifications of the existing threaded holes necessary
- System is compatible with press brakes with automatic crowning tables

Directly on a 90 mm wide press brake table \*

- Use of existing holes for the standard clamp plates (hole distance 100 mm)
- In alternative, modification of the existing threaded holes may be necessary to use Rolleri R1 type dies with 60 mm base, two ground 15 mm wide shims are supplied to be inserted into the die holder and secured with pins
- Thanks to the rubber inserts, short die segments are perfectly clamped

\* See page 54 - 56 - 58

1a. Is your press brake table like this one?

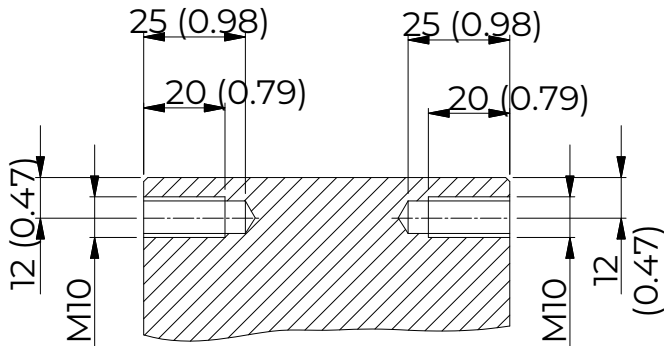
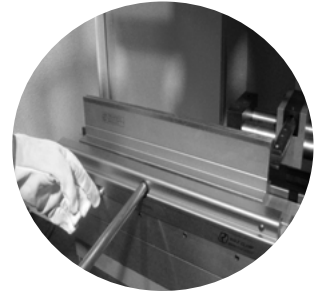

NO  
dies with base 60 mm

● ROL2 MAN 60-C

NO  
dies with base 90 mm

● ROL2 MAN 90-C

1b. Is it possible to make the holes as per below drawing on your press brake?

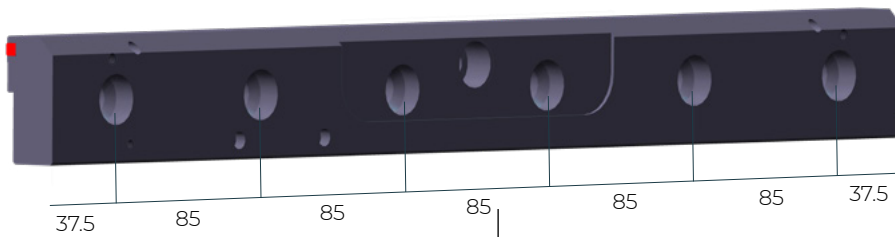

NO  
90 mm  
table

NO  
60 mm  
table

YES

2. Do you have rear holder?

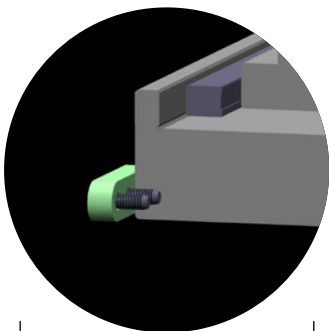

NO  
60 mm table

● ROL2 CLAMP1 MAN

NO  
90 mm table

● ROL2 CLAMP1 MAN 90

YES  
60 mm table

YES  
90 mm table

ROL2 CLAMP1 MAN-F ROL2 CLAMP1 MAN 90-F



## 60 MM DIES

### ROL2 MAN 60-C

Press brake table > 90 mm

L (mm)	H (mm)	Weight
1075 mm	40 mm	37 kg

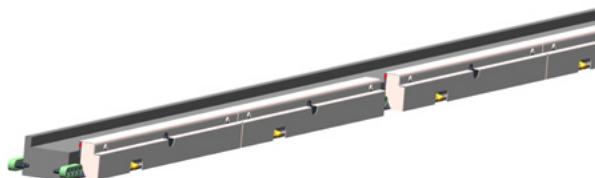

- Die Holder
- Front Clamp

### ROL2 CLAMP1 MAN

Press brake table = 60 mm

L (mm)	H (mm)	Weight
500 mm	-	13 kg



- Front Clamp (You need 2 front clamps for meter)
- Rear Clamp

### ROL2 CLAMP1 MAN-F

Press brake table = 60 mm

L (mm)	H (mm)	Weight
500 mm	-	8 kg



- Front Clamp (You need 2 front clamps for meter)

## 90 MM DIES

### ROL2 MAN 90-C

Press brake table > 90 mm

L (mm)	H (mm)	Weight
1075 mm	40 mm	48 kg

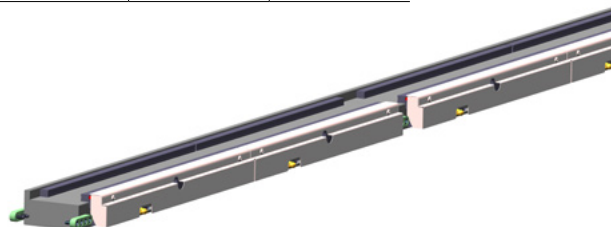

- Die Holder
- Front Clamp
- Shims

### ROL2 CLAMP1 MAN 90

Press brake table = 90 mm

L (mm)	H (mm)	Weight
500 mm	-	16 kg



- Front Clamp (You need 2 front clamps for meter)
- Rear Clamp
- Shims

### ROL2 CLAMP1 MAN 90-F

Press brake table = 90 mm

L (mm)	H (mm)	Weight
500 mm	-	11 kg

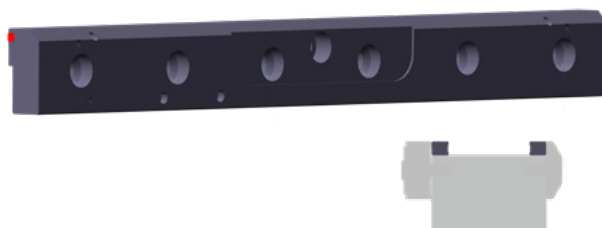

- Front Clamp (You need 2 front clamps for meter)
- Shims

R1

1a. Is your press brake table like this one?

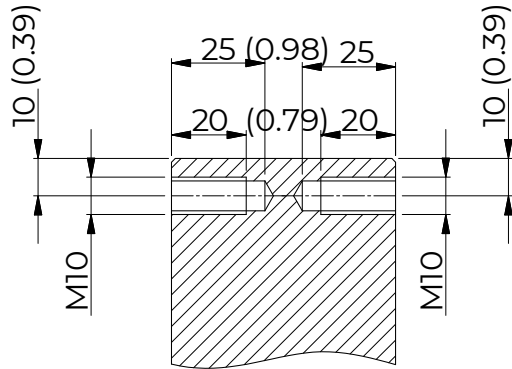

NO  
dies with base 60 mm  
● ROL2 HYD 60-C

NO  
dies with base 90 mm  
● ROL2 HYD 90-C

1b. Is it possible to make the holes as per below drawing on your press brake?

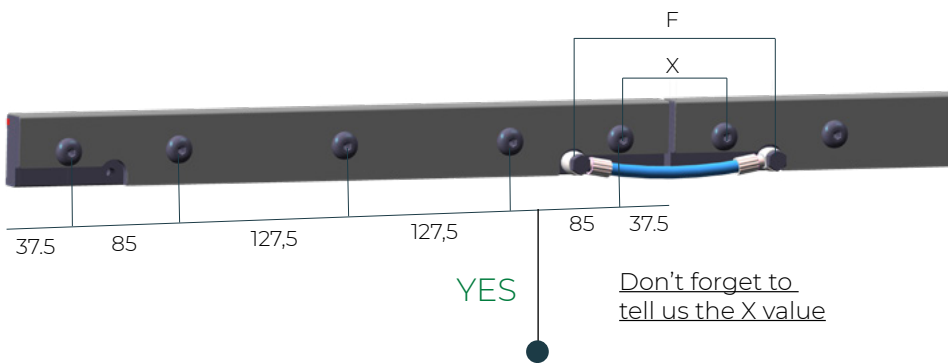

NO  
90 mm  
table

NO  
60 mm  
table

YES

Don't forget to  
tell us the X value

2. Do you have rear holder?

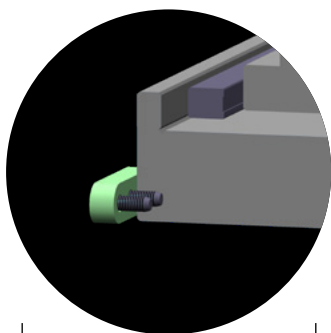

NO  
60 mm table

NO  
90 mm table

● ROL2 CLAMP1 HYD

● ROL2 CLAMP1 HYD 90

YES  
60 mm table

YES  
90 mm table

ROL2 CLAMP1 HYD-F

ROL2 CLAMP1 HYD 90-F

CONTROL UNIT  
HPU - E/80  
see page 10



## 60 MM DIES

### ROL2 HYD 60-C

Press brake table > 90 mm

L (mm)	H (mm)	Weight	Bar 80
1075 mm	36 mm	32 kg	

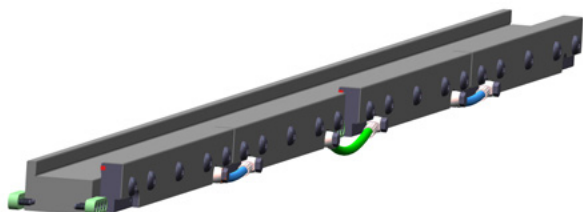

- Die Holder
- Front Clamp (You need 2 front clamps for meter)

### ROL2 CLAMP1 HYD

Press brake table = 60 mm

L (mm)	H (mm)	Weight	Bar 80
500 mm	-	14 kg	

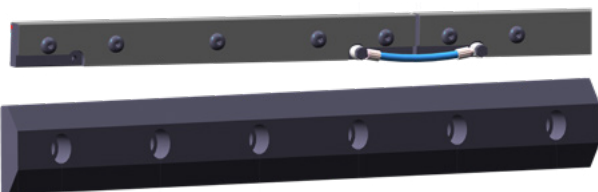

- Front Clamp (You need 2 front clamps for meter)
- Rear Clamp

### ROL2 CLAMP1 HYD-F

Press brake table = 60 mm

L (mm)	H (mm)	Weight	Bar 80
500 mm	-	9.5 kg	



- Front Clamp (You need 2 front clamps for meter)

## 90 MM DIES

### ROL2 HYD 90-C

Press brake table > 90 mm

L (mm)	H (mm)	Weight	Bar 80
1075 mm	36 mm	45 kg	

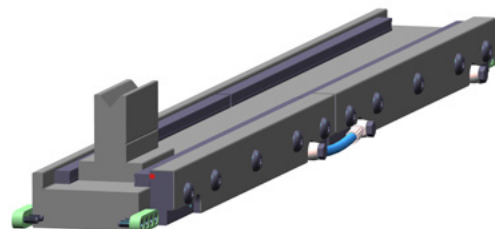

- Die Holder
- Front Clamp (You need 2 front clamps for meter)
- Shims

### ROL2 CLAMP1 HYD 90

Press brake table = 90 mm

L (mm)	H (mm)	Weight	Bar 80
500 mm	-	17 kg	

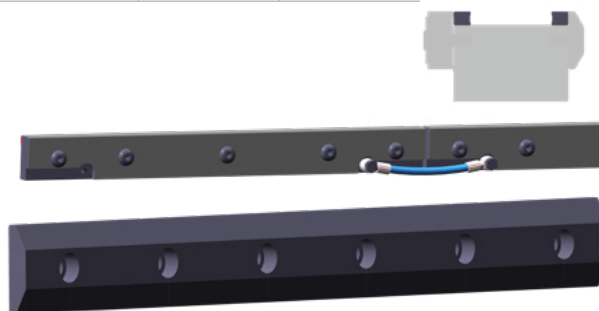

- Front Clamp (You need 2 front clamps for meter)
- Rear Clamp
- Shims

### ROL2 CLAMP1 HYD 90-F

Press brake table = 90 mm

L (mm)	H (mm)	Weight	Bar 80
500 mm	-	12.5 kg	



- Front Clamp (You need 2 front clamps for meter)
- Shims

R1

1a. Is your press brake table like this one?

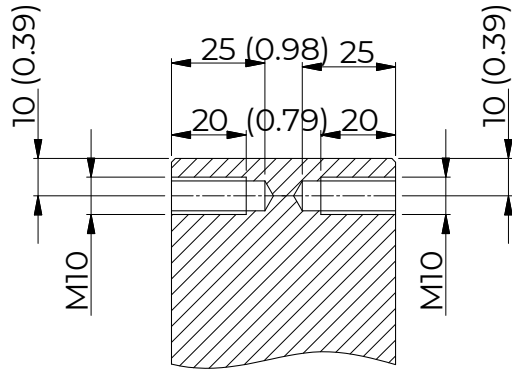

NO  
dies with base 60 mm —● ROL2 PN 150-60-C

NO  
dies with base 90 mm —● ROL2 PN 150-90-C

1b. Is it possible to make the holes as per below drawing on your press brake?

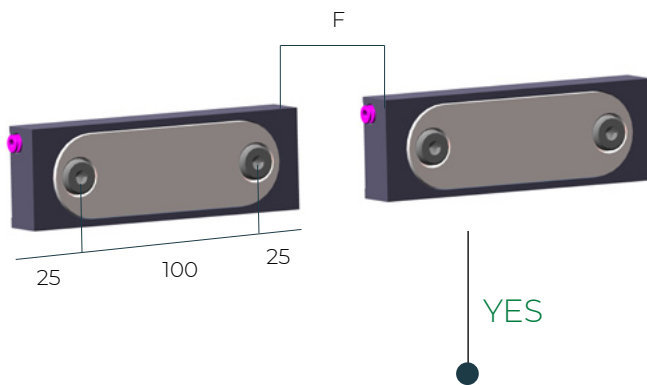

NO  
90 mm  
table

NO  
60 mm  
table

2. Do you have rear holder?

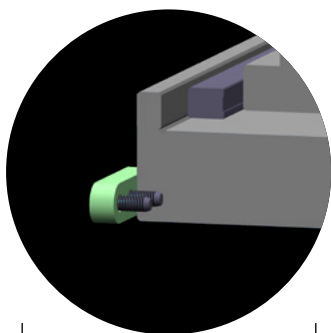

NO  
60 mm table

NO  
90 mm table

YES  
60 mm table

YES  
90 mm table

● ROL2 CLAMP1 PN 150

● ROL2 CLAMP1 PN 150-90

ROL2 CLAMP1 PN-F

ROL2 CLAMP1 PN 90-F

CONTROL UNIT  
ROL1 PDU MOL  
see page 11



### 60 MM DIES

#### ROL2 PN 150-60-C

Press brake table > 90 mm

L (mm)	H (mm)	Weight	Bar 12
1075 mm	36 mm	31.6 kg	



- Die Holder
- Front Clamp

#### ROL2 CLAMP1 PN 150

Press brake table = 60 mm

L (mm)	H (mm)	Weight	Bar 12
3 x 150 mm	Front	14 kg	
500 mm	Rear		

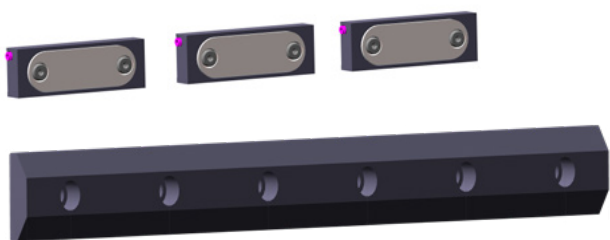

- Front Clamp (You need 6 front clamps for meter)
- Rear Clamp

#### ROL2 CLAMP1 PN-F

Press brake table = 60 mm

L (mm)	H (mm)	Weight	Bar 12
150 mm	-	9 kg	



- Front Clamp (You need 6 front clamps for meter)

### 90 MM DIES

#### ROL2 PN 150-90-C

Press brake table > 90 mm

L (mm)	H (mm)	Weight	Bar 12
1075 mm	36 mm	44 kg	

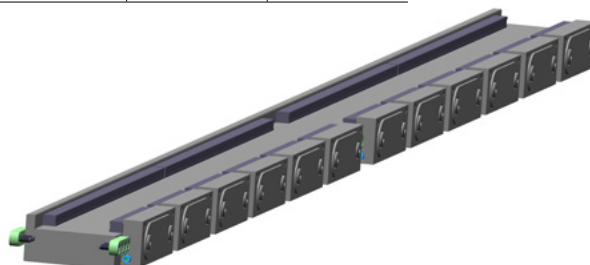

- Die Holder
- Front Clamp
- Shims

#### ROL2 CLAMP1 PN 150-90

Press brake table = 90 mm

L (mm)	H (mm)	Weight	Bar 12
3 x 150 mm	Front	17 kg	
500 mm	Rear		

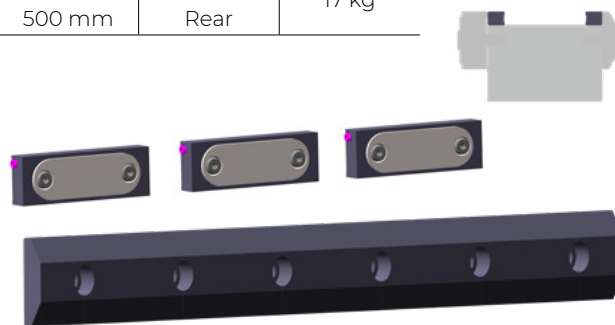

- Front Clamp (You need 6 front clamps for meter)
- Rear Clamp
- Shims

#### ROL2 CLAMP1 PN 90-F

Press brake table = 90 mm

L (mm)	H (mm)	Weight	Bar 12
150 mm	-	12 kg	



- Front Clamp (You need 6 front clamps for meter)
- Shims

R1

CTS

Do you need to make your press brake table higher?

C45: 560-710 N/mm<sup>2</sup>

1000 kN/m max.

CTS

L (mm)	H (mm)	Weight
835 mm	55 mm	29 kg

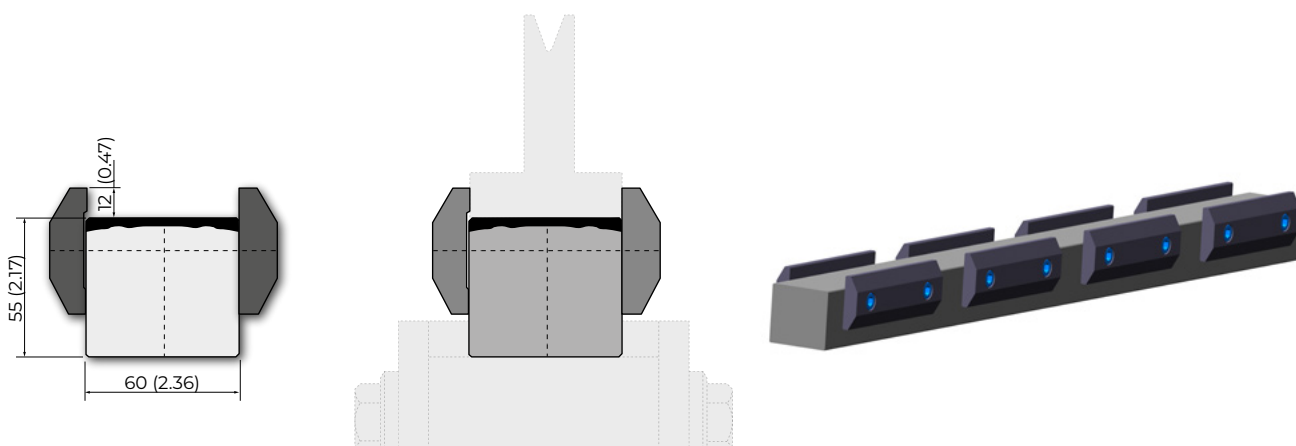

### ROL2 PN CTS

Press brake table 60 mm

L (mm)	H (mm)	Weight	Bar 12
835 mm	55 mm	30.6 kg	

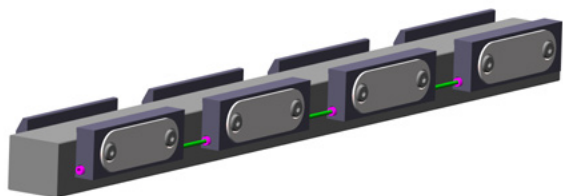

- CTS
- Pneumatic Front Clamp







## SYSTEMS FOR ROLLERI TOOLS R2

### ▼ COMPATIBILITY

Darley

LVD

Safan

Trumpf

Press brake machines with System NSCL

**UPPER**

W ROL

64 - 67

**LOWER**

W ROL 2

68 - 69



- ▶ Vertical tool change of punches with:
  - ROL1 System
  - QuickLock System
- ▶ Horizontal tool change of punches with safety pins
- ▶ Improvement in productivity
- ▶ Upper tang is produced according to your press brake

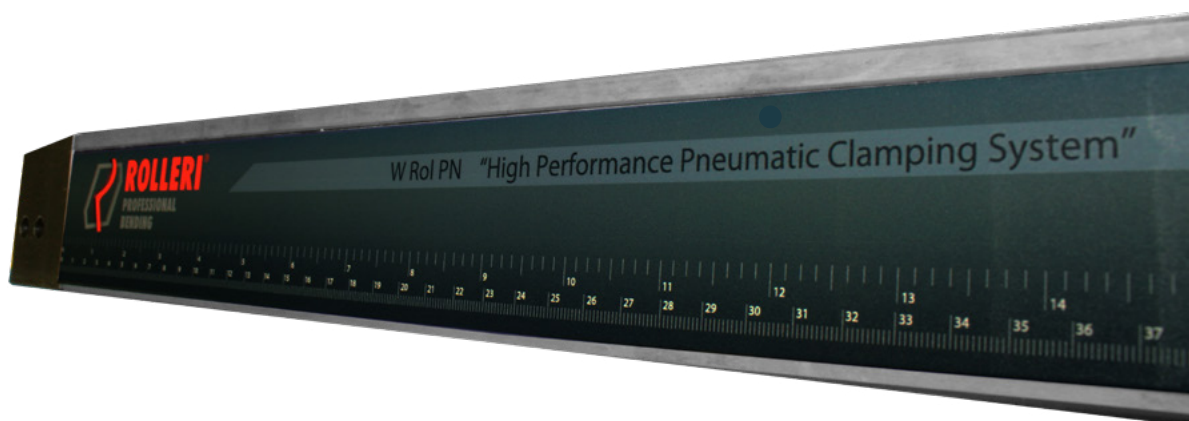

Vertical Tool change	●
Horizontal tool change	
Automatic tool alignment	●
Tools modifications required	
Antifall system	●
Pneumatic version	●
Hydraulic version	●
Manual version	

- ▶ Fast tool change
- ▶ Time-saving system
- ▶ Reduced production costs
- ▶ Significantly increased profitability
- ▶ Improved competitiveness

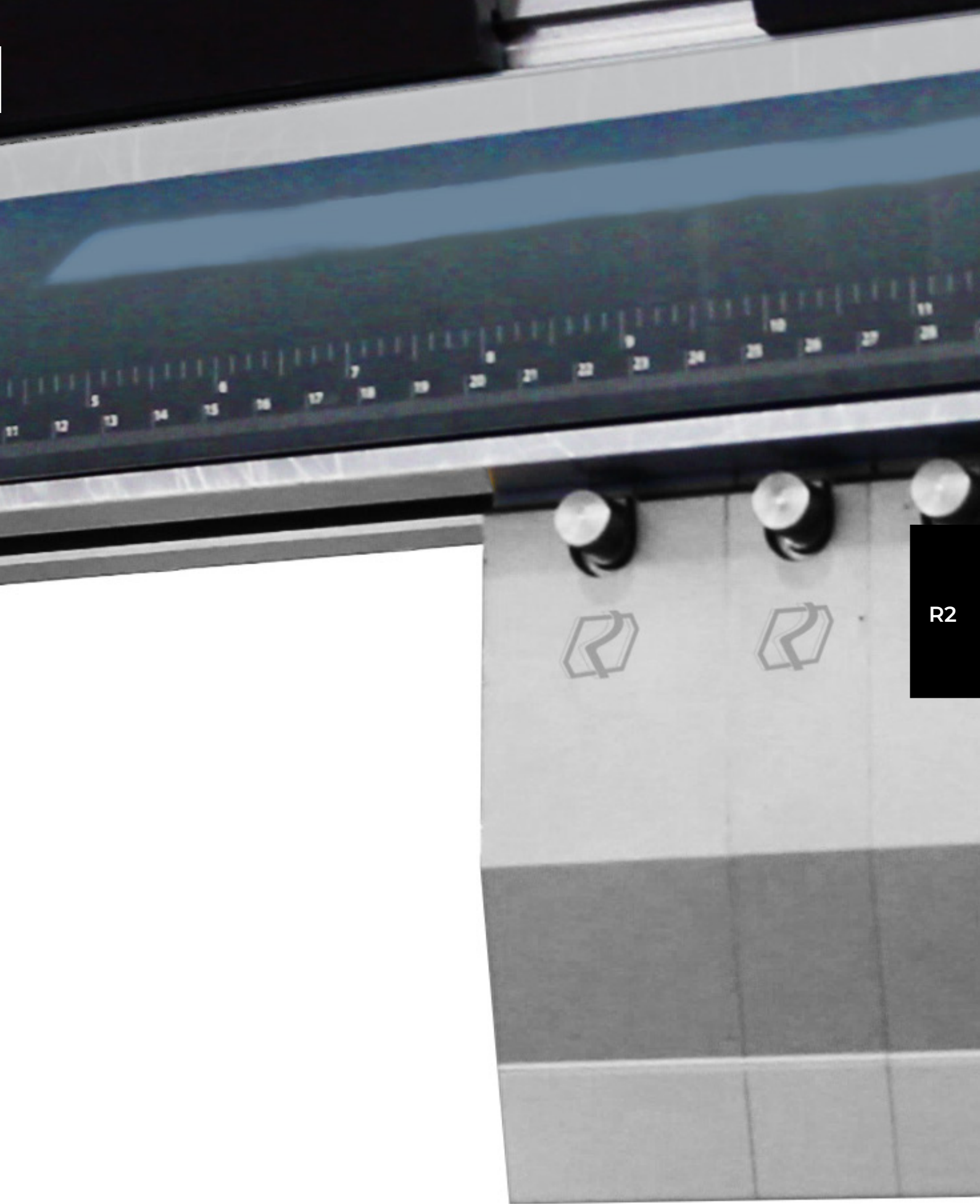

R2

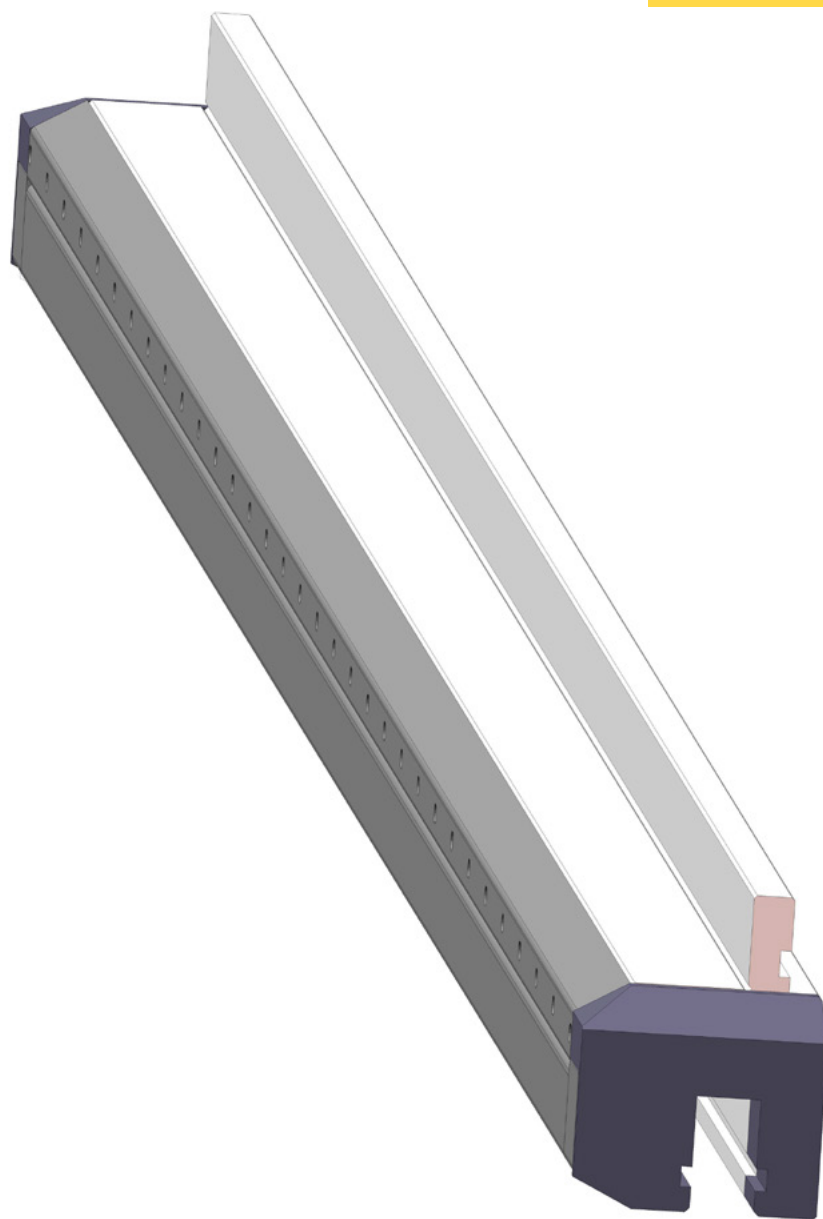
42Cr: 900-1150 N/mm<sup>2</sup>

Length	Weight
1550 mm	42.2 kg
2100 mm	57.1 kg
2550 mm	69.4 kg
3100 mm	84.3 kg
4100 mm	111.5 kg

#### HPU-E/80

- ▶ To be connected to CNC for open-close function
- ▶ Gives electric signal to CNC in case of lowering pressure, setting press brake in Alarm stop
- ▶ Works on 220-380 volt
- ▶ Max pressure 80 bar
- ▶ 15 lit oil pump



## W ROL PN

Bar 12

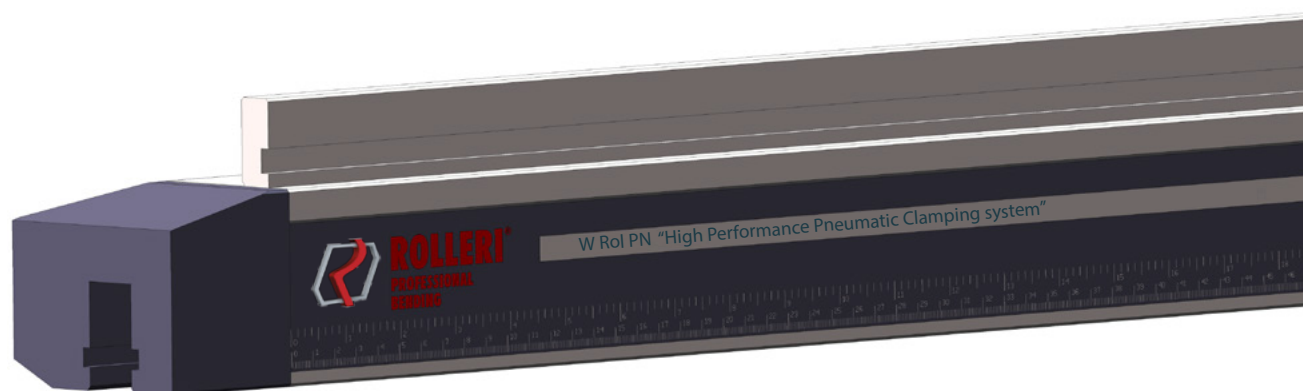

42Cr: 900-1150 N/mm<sup>2</sup>

Length	Weight
1550 mm	42.2 kg
2100 mm	57.1 kg
2550 mm	69.4 kg
3100 mm	84.3 kg
4100 mm	111.5 kg

R2

### PDU MOLT

- ▶ Controls air pressure at entrance & at end of line of circuit
- ▶ Multiplies air from compressor to ensure best clamp closure
- ▶ Gives electric signal to CNC in case of lowering pressure, setting press brake in Alarm stop
- ▶ All intermediates are connected to each other through pneumatic pipes and work with air at 12 bar to guarantee high clamping force

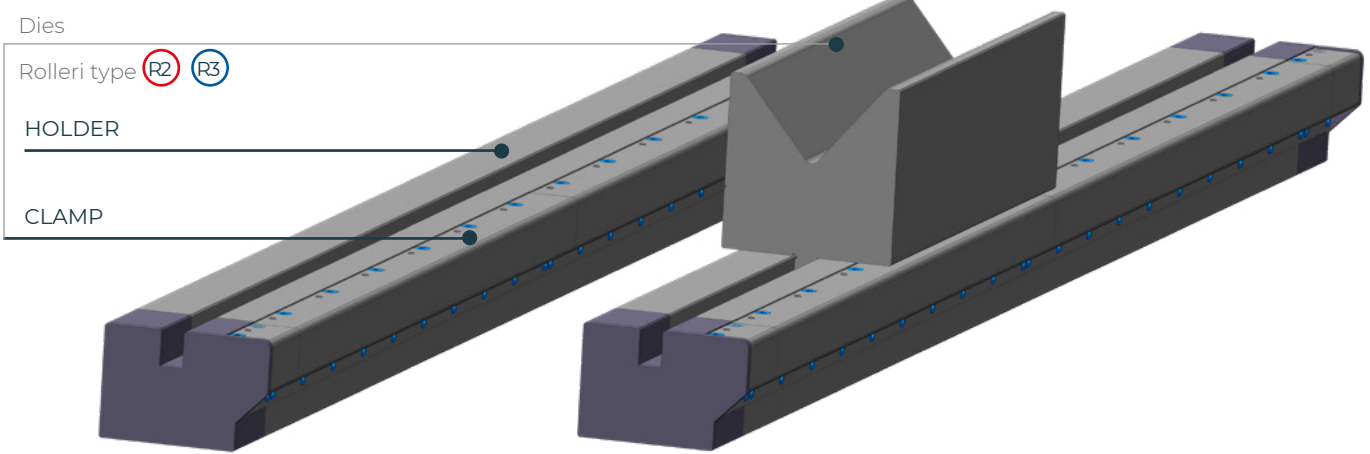

Automatic tool alignment	
R2/R3 Tools modifications required	
Pneumatic version	●
Hydraulic version	●
Manual version	



### W ROL2 PN

Pneumatic version

Bar 12

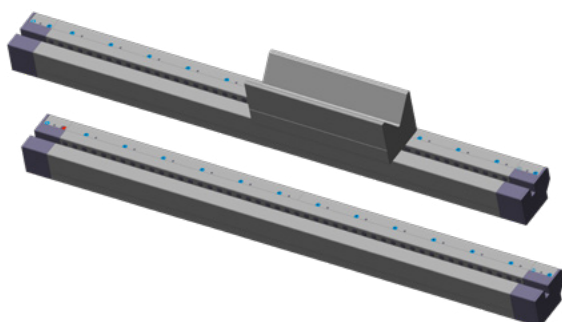

### W ROL2 HYD

Hydraulic version

Bar 30

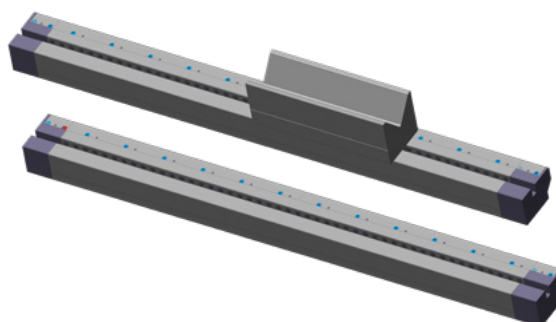

Length	incl. Die holder	Weight
1550 mm		48.1 kg
2100 mm		65.1 kg
2550 mm		79.1 kg
3100 mm		96.1 kg
4100 mm		127.1 kg

Length	incl. Die holder	Weight
1550 mm		48.1 kg
2100 mm		65.1 kg
2550 mm		79.1 kg
3100 mm		96.1 kg
4100 mm		127.1 kg

R2

#### ROLI PDU MOLT

- ▶ Controls air pressure at entrance & at end of line of circuit
- ▶ Multiplies air from compressor to ensure best clamp closure.
- ▶ Gives electric signal to CNC in case of lowering pressure, setting press brake in Alarm stop
- ▶ All intermediates are connected to each other through pneumatic pipes and work with air at 12 bar to guarantee high clamping force

#### HPU-E/30

- ▶ To be connected to CNC for open-close function
- ▶ Gives electric signal to CNC in case of lowering pressure, setting press brake in Alarm stop
- ▶ Works on 220-380 volt
- ▶ Pressure 80 bar/ Pressure 30 bar
- ▶ 15 lit oil pump



## SYSTEMS FOR ROLLER TOOLS R3 - R4 - RX

### ▼ COMPATIBILITY

Bystronic Beyeler:

RFA

RF

R

S

LVD

Ajjal-Axial

Colgar

Colly

EHT

Ursviken

Weinbrenner

American 

**UPPER**

ROL 3

72 - 75

**R3  
R4  
RX**



- ▶ Can be used on press brakes with different tang types
- ▶ Possible customization upon request
- ▶ Improvement in productivity

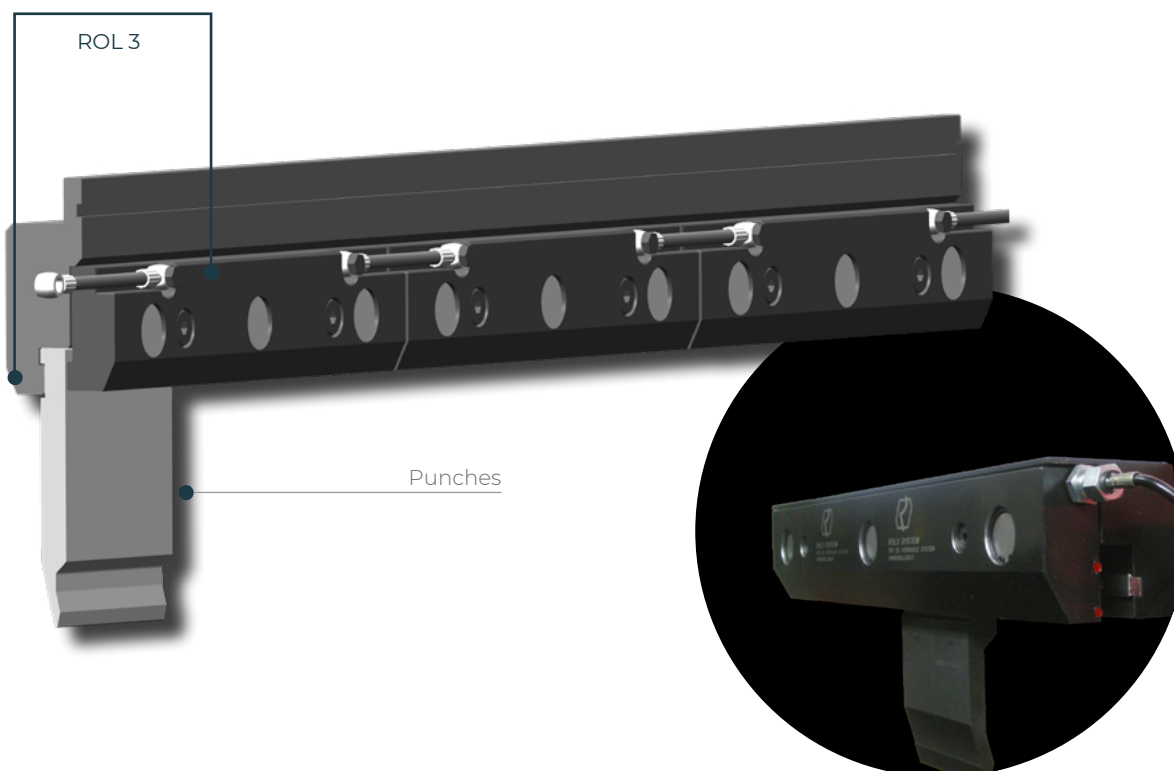

Vertical Tool change	●	R3
Horizontal tool change	●	R3 R4 R American
Automatic tool alignment	●	R3
Pneumatic version		
Hydraulic version	●	
Manual version		

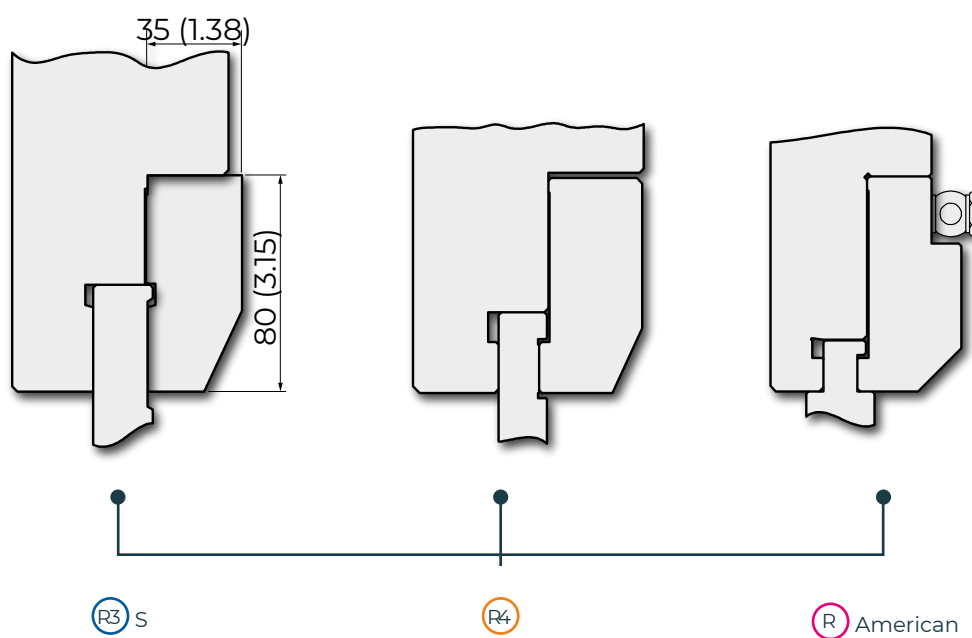
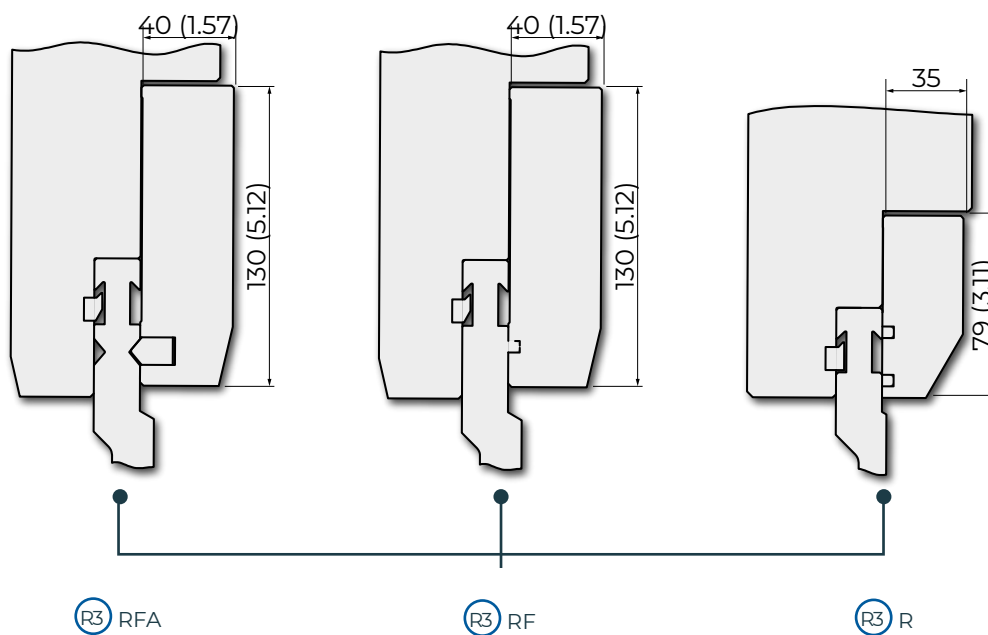

R3  
R4  
RX

ROL3

**ROL3 HYD**

Bar 120-160



Length	500 mm
--------	--------

---

HPU-E

- ▶ To be connected to CNC for open-close function
- ▶ Gives electric signal to CNC in case of lowering pressure, setting press brake in Alarm stop
- ▶ Works on 220-380 volt
- ▶ Max pressure 160 bar
- ▶ 15 lit oil pump





R3  
R4  
RX



# SYSTEMS FOR TOOLS TYPE AMERICAN

## ▼ COMPATIBILITY

American



## UPPER

Intermediates	78 - 79
UNIVERSAL FAST CLAMP	80 - 81
UNIVERSAL EASY CLAMP	82 - 83

# Intermediates - R American Tang

C45: 560-710 N/mm<sup>2</sup>

1000 kN/m max.

## INT100-A / INT120-A

	L (mm)	Weight
INT100-A	150 mm	3,5 kg
INT120-A	150 mm	5,2 kg

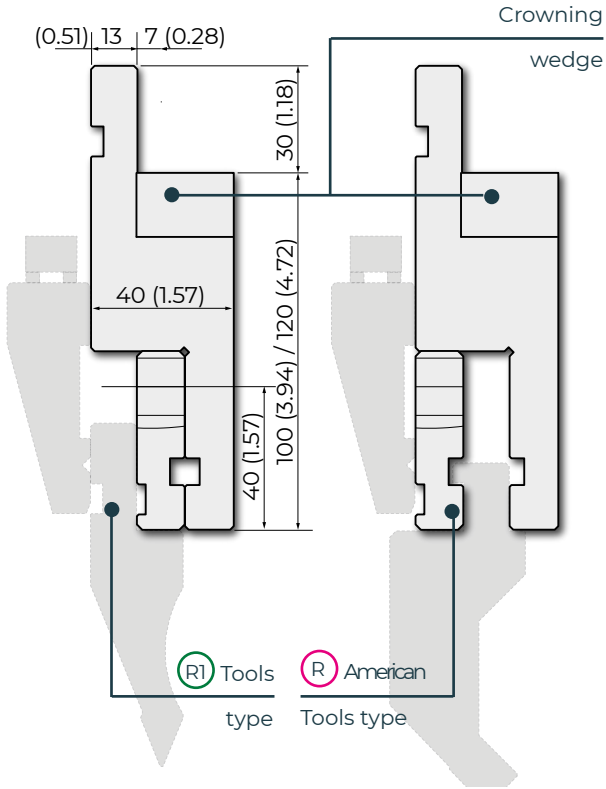

C45: 560-710 N/mm<sup>2</sup>

1000 kN/m max.

## INT100-A (American)

	L (mm)	Weight
INT100-A	150 mm	3,5 kg

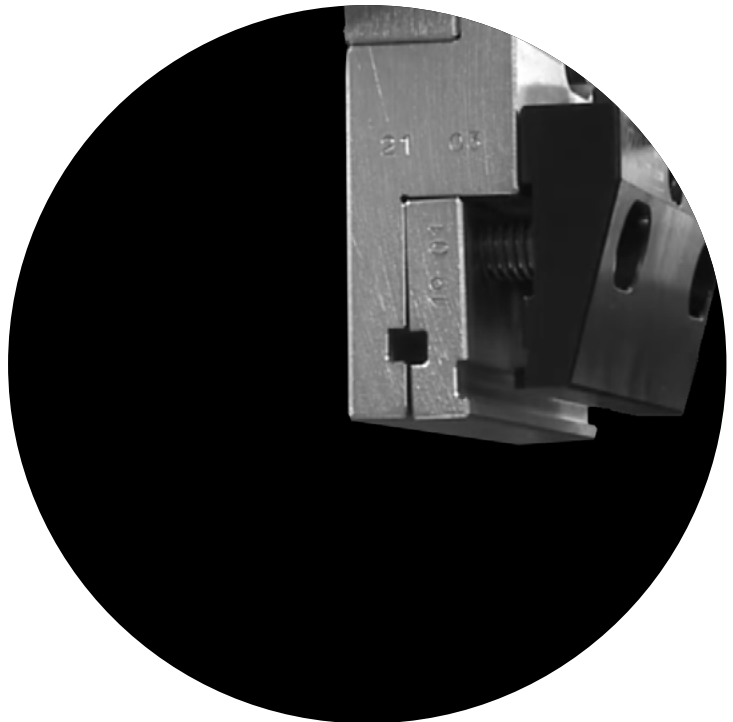
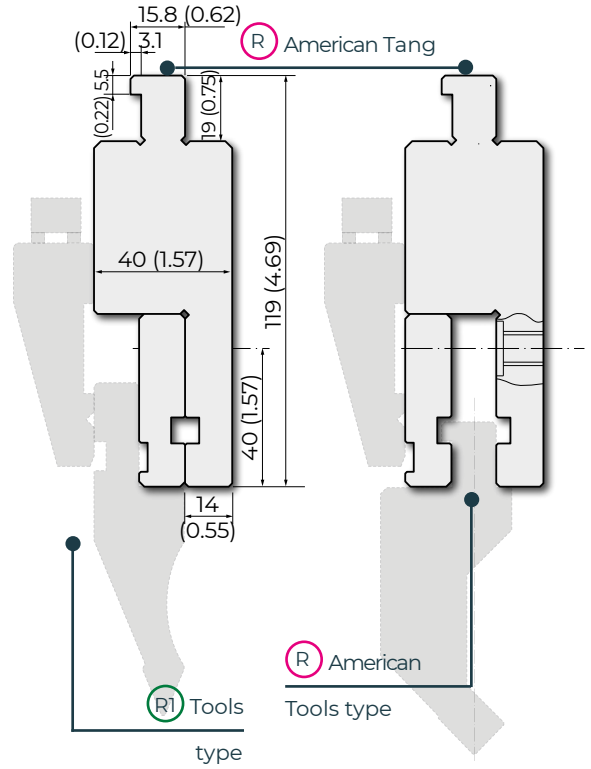



C45: 560-710 N/mm<sup>2</sup>

1000 kN/m max.

### INT120-40-A

	L (mm)	Weight
INT120-40A	150 mm	6,0 kg

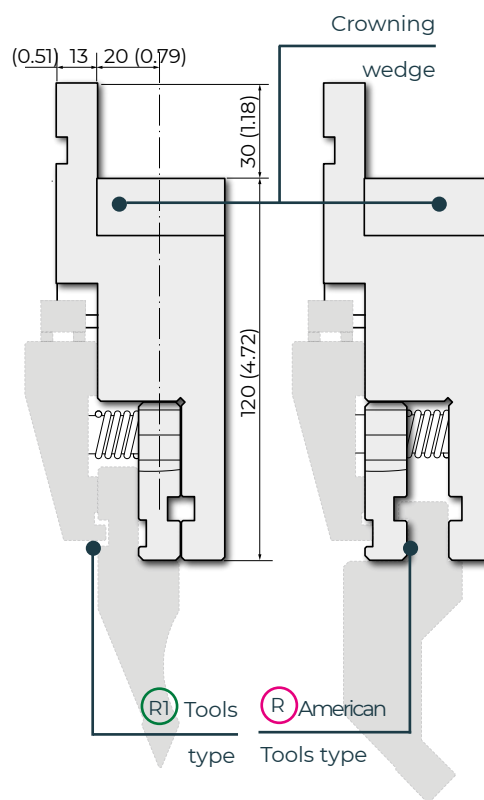

R  
Am

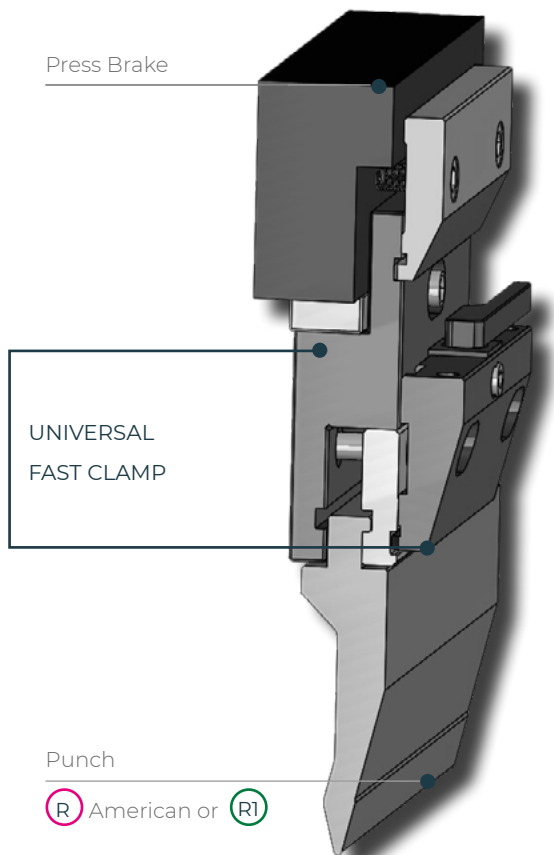

- ▶ R American Tools Type
- ▶ R1 Tools Type
- ▶ Available with 7 or 20 mm distance from tag
- ▶ Closing by screw with CLAMP3 plate
- ▶ Made in C45 Steel

Vertical Tool change	
Horizontal tool change	●
Automatic tool alignment	
R1/R American Tools modifications required	
Antifall system	●
Intermediate included	●
Pneumatic version	
Hydraulic version	
Manual version	●

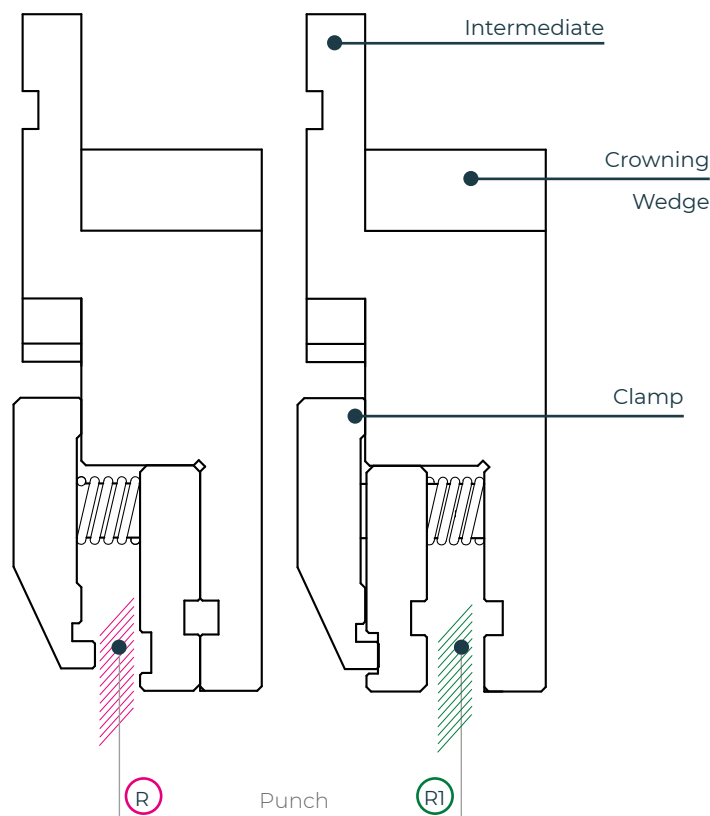

## Universal Fast clamp

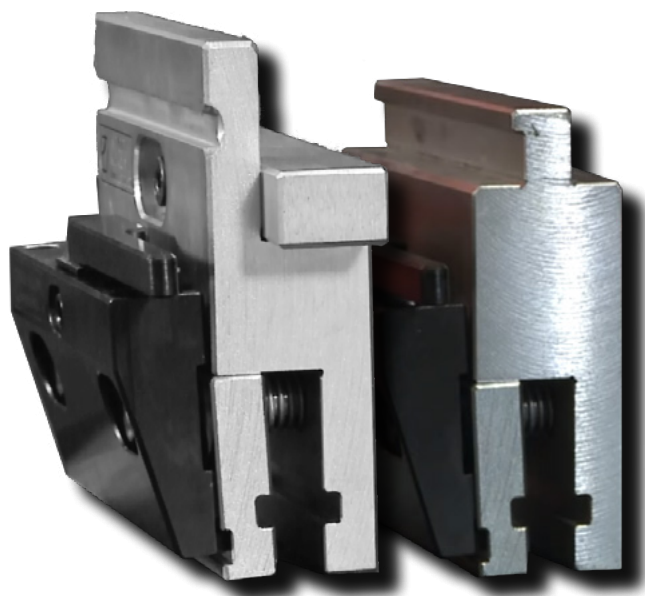

Length	150 mm
Height	100 / 120 mm

Intermediates	Comp.
Without intermediate	
INT100-A	●
INT100 American	●



R  
Am



- ▶ Closing by screw with ST60 plate
- ▶ Suits: R American style tools & R1 style tools
- ▶ Upper Ram of PB: European Style Z1 or Z2
- ▶ Made in C45 Steel

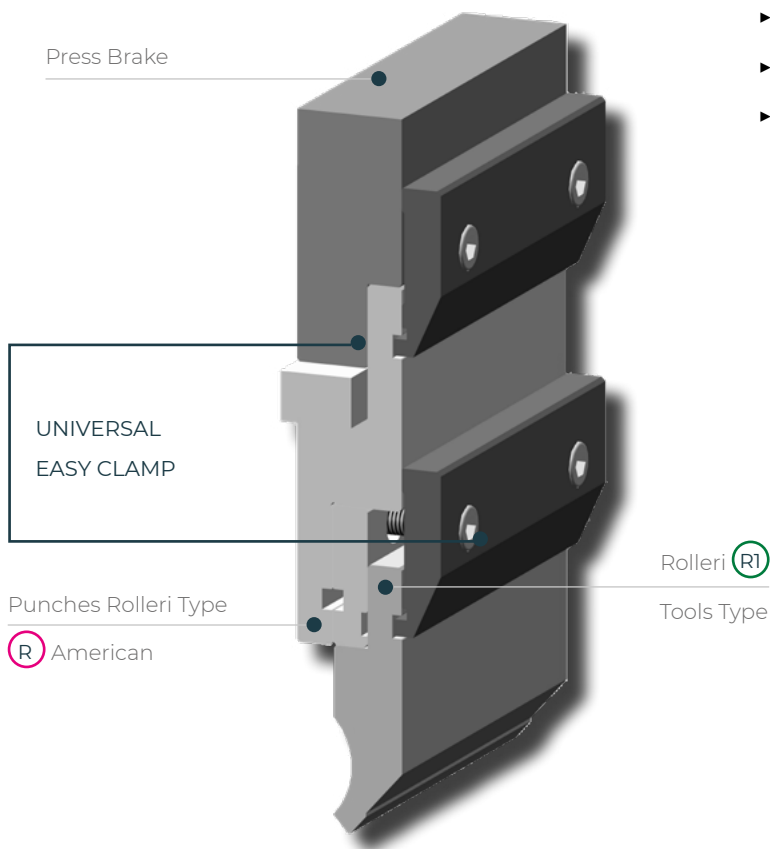

Vertical Tool change	
Horizontal tool change	●
Automatic tool alignment	
R1/R American Tools modifications required	
Antifall system	●
Intermediate included	●
Pneumatic version	
Hydraulic version	
Manual version	●

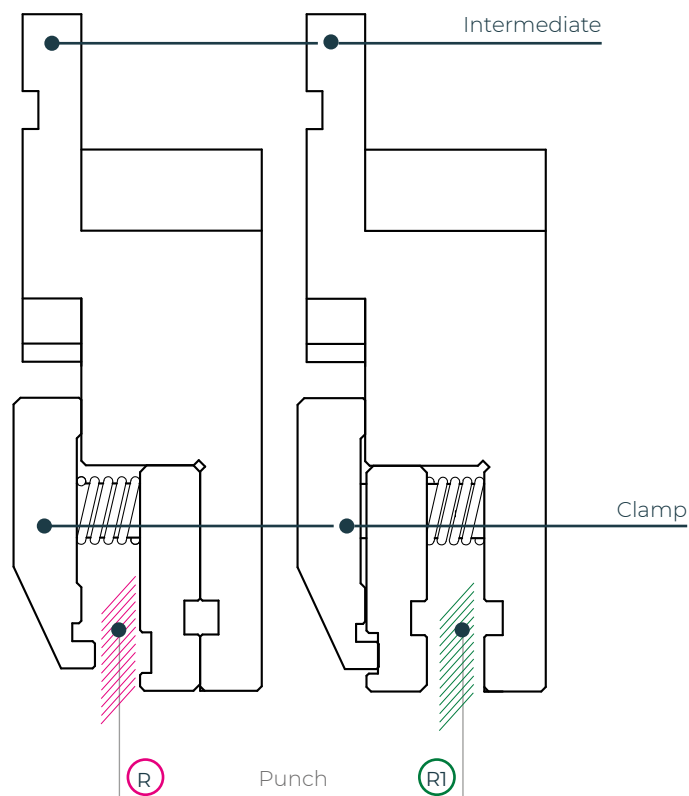

## Universal Easy Clamp



Length	150 mm
Height	100 / 120 mm

Intermediates	Comp.
Without intermediate	
INT100 - A	●
INT120 - 40 - A	●

R  
Am



## CROWNING TABLE



Overview	86 - 87
ROL Crowning Table <span>R1</span>	88
ROL Crowning Table <span>R2</span> <span>R3</span> <span>R4</span> <span>RX</span>	89
Necessary information	90 - 91

## ROL crowning table

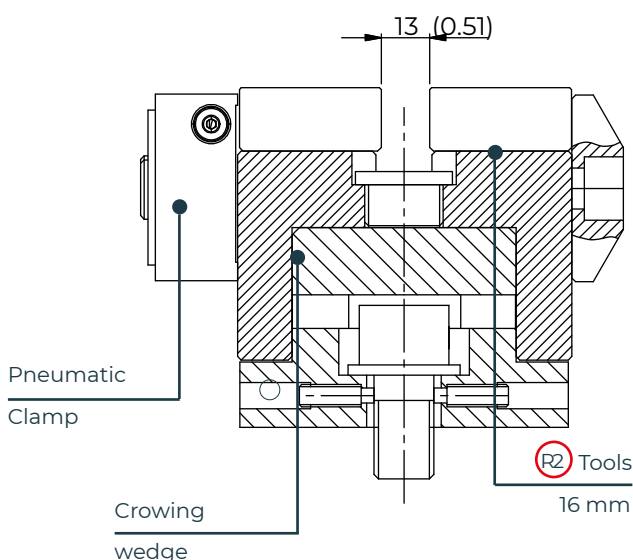
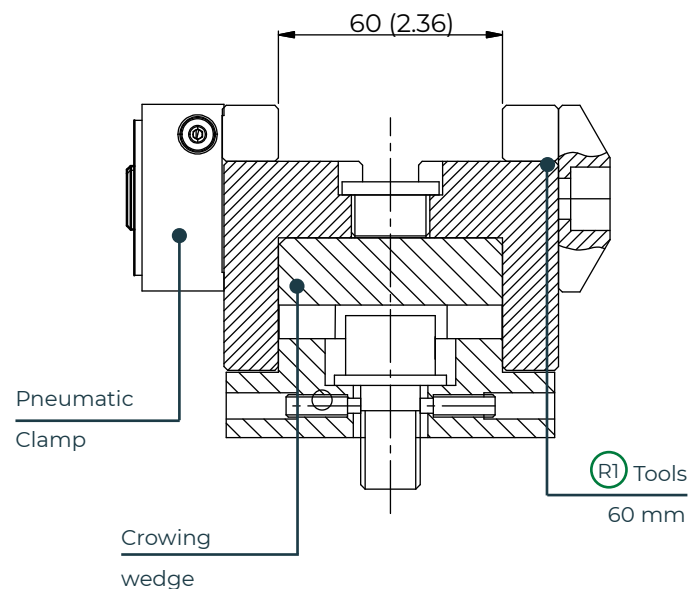
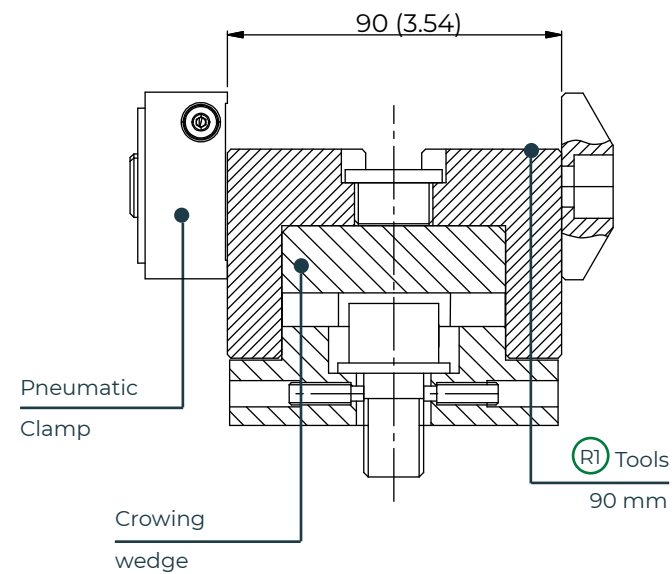

Rolleri crowning tables provide mechanical compensation to the deflections occurring during the bending process. Deflection depends on bending length and on ratio between sheet metal thickness and die opening.

This system is composed by a special rod, which is placed between opposite wedges. Each wedge can be calibrated autonomously to compensate localized deflection. The rod can be manually driven or by a motoreducer controlled by the press brake CNC.

The adjustment of the crowning table is a fast and accurate procedure to carry out before bending.

The crowning table is produced according to the press brake features to optimize its working and its integration to the press brake it is installed in. Rolleri crowning table can be designed to clamp R1 dies with 60mm and 90mm base or R2 dies with 13mm tang and it's supplied with all accessories necessary to mount and align it to the upper beam.

On request, Rolleri crowning table can be equipped with pneumatic clamping systems for lower tools.

### ADVANTAGES

- ▶ You can adjust deflection of the whole length of the press brake or just a short section thanks to independent wedges
- ▶ Very precise bending angles
- ▶ R1 type dies with 60 mm and 90 mm base can be clamped as well as R2 dies with 13 mm tang
- ▶ Automatic crowning through connection to press brake CNC or manual crowning with a handle
- ▶ This crowning table can be installed in new press brakes or to retrofit old press brakes
- ▶ Precise positioning and alignment of the crowning table onto the press brake table
- ▶ Easy and fast usage



	Dies						Version	
	R1	R2	R3	R4	RX	R American	Manual	Automatic
ROL TM R1	●						●	
ROL TM R2		●	●	●	●	●	●	
ROL TA R1	●							●
ROL TA R2		●	●	●	●	●		●

TAB

## ROL Crowning table

### ROL TA R1

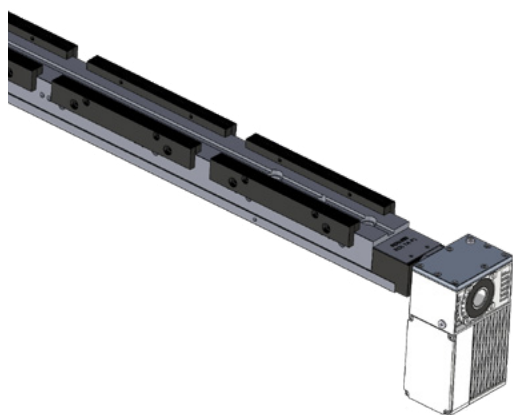

Automatic	●
Manual	
Dies Type <span style="border: 1px solid green; border-radius: 50%; padding: 2px;">R1</span>	●
Dies Type <span style="border: 1px solid red; border-radius: 50%; padding: 2px;">R2</span>	
Dies Type <span style="border: 1px solid blue; border-radius: 50%; padding: 2px;">R3</span>	

Length	Weight
1100 mm	77 kg/m
2100 mm	147 kg/m
3100 mm	217 kg/m
4100 mm	287 kg/m

### ROL TM R1

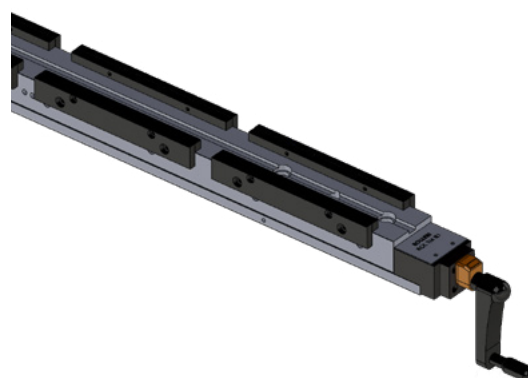

Automatic	
Manual	●
Dies Type <span style="border: 1px solid green; border-radius: 50%; padding: 2px;">R1</span>	●
Dies Type <span style="border: 1px solid red; border-radius: 50%; padding: 2px;">R2</span>	
Dies Type <span style="border: 1px solid blue; border-radius: 50%; padding: 2px;">R3</span>	

Length	Weight
1100 mm	77 kg/m
2100 mm	147 kg/m
3100 mm	217 kg/m
4100 mm	287 kg/m

- The crowning table is driven by a motoreducer controlled by the press brake CNC



### ROL TA R2

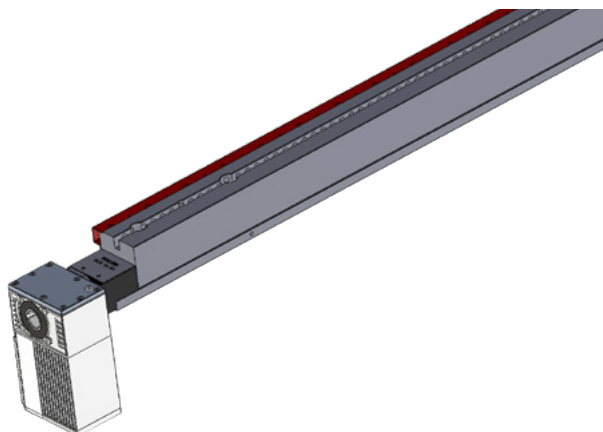

### ROL TM R2

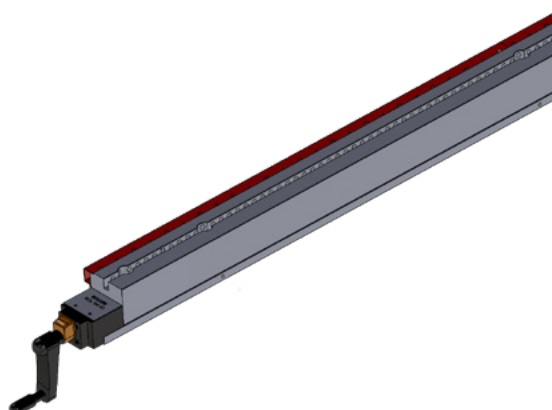

Automatic	●
Manual	
Dies Type <b>R1</b>	
Dies Type <b>R2</b>	●
Dies Type <b>R3</b>	●

Automatic	
Manual	●
Dies Type <b>R1</b>	
Dies Type <b>R2</b>	●
Dies Type <b>R3</b>	●

Length	Weight
1100 mm	79.2 kg/m
2100 mm	151.2 kg/m
3100 mm	223.2 kg/m
4100 mm	295.2 kg/m

Length	Weight
1100 mm	79.2 kg/m
2100 mm	151.2 kg/m
3100 mm	223.2 kg/m
4100 mm	295.2 kg/m

The crowning table is driven by a motoreducer controlled by the press brake CNC

Our Technical office can make a customized drawing based on your press brake!  
Contact us [sales@rolleri.it](mailto:sales@rolleri.it)

TAB

Necessary Information

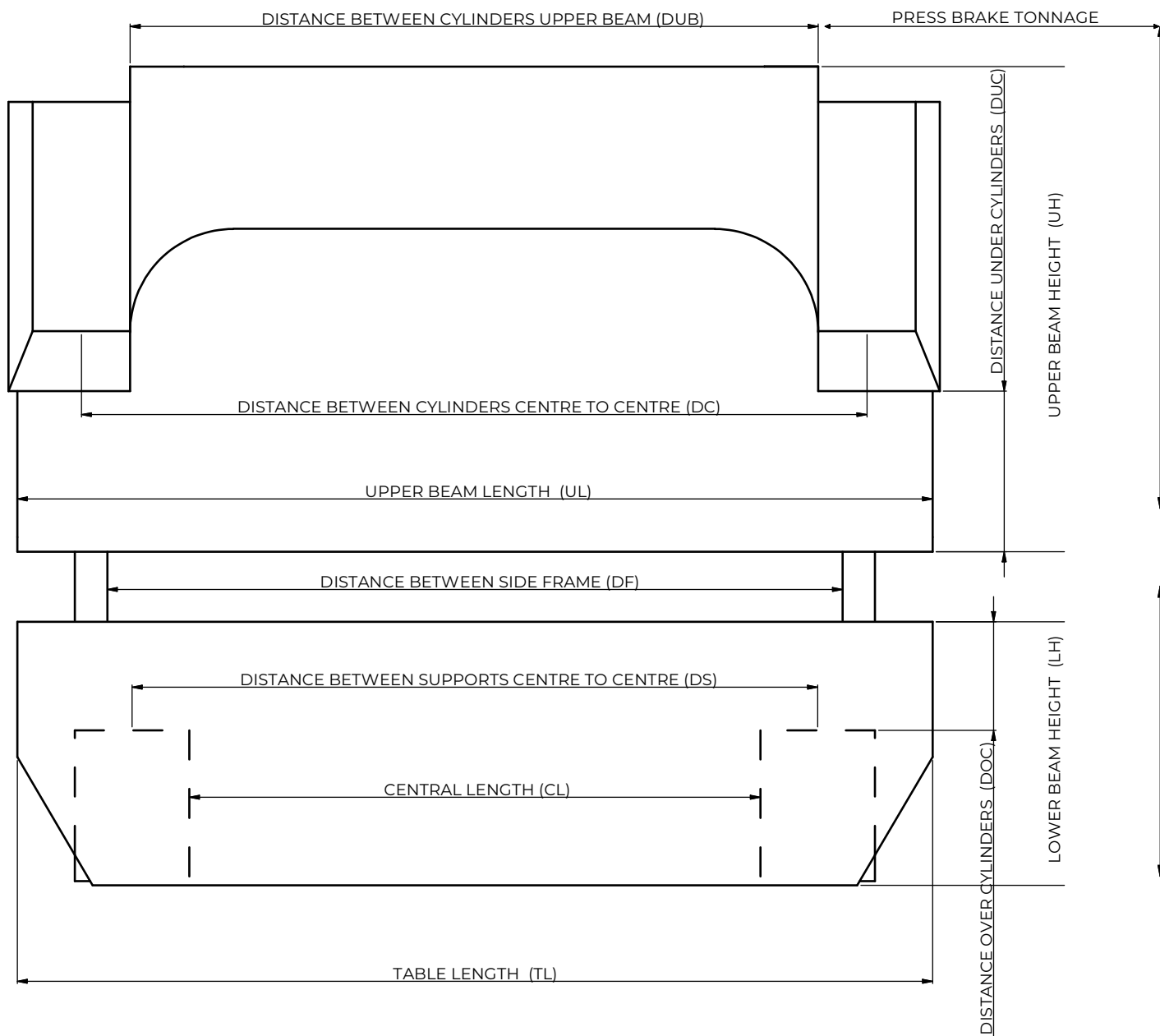

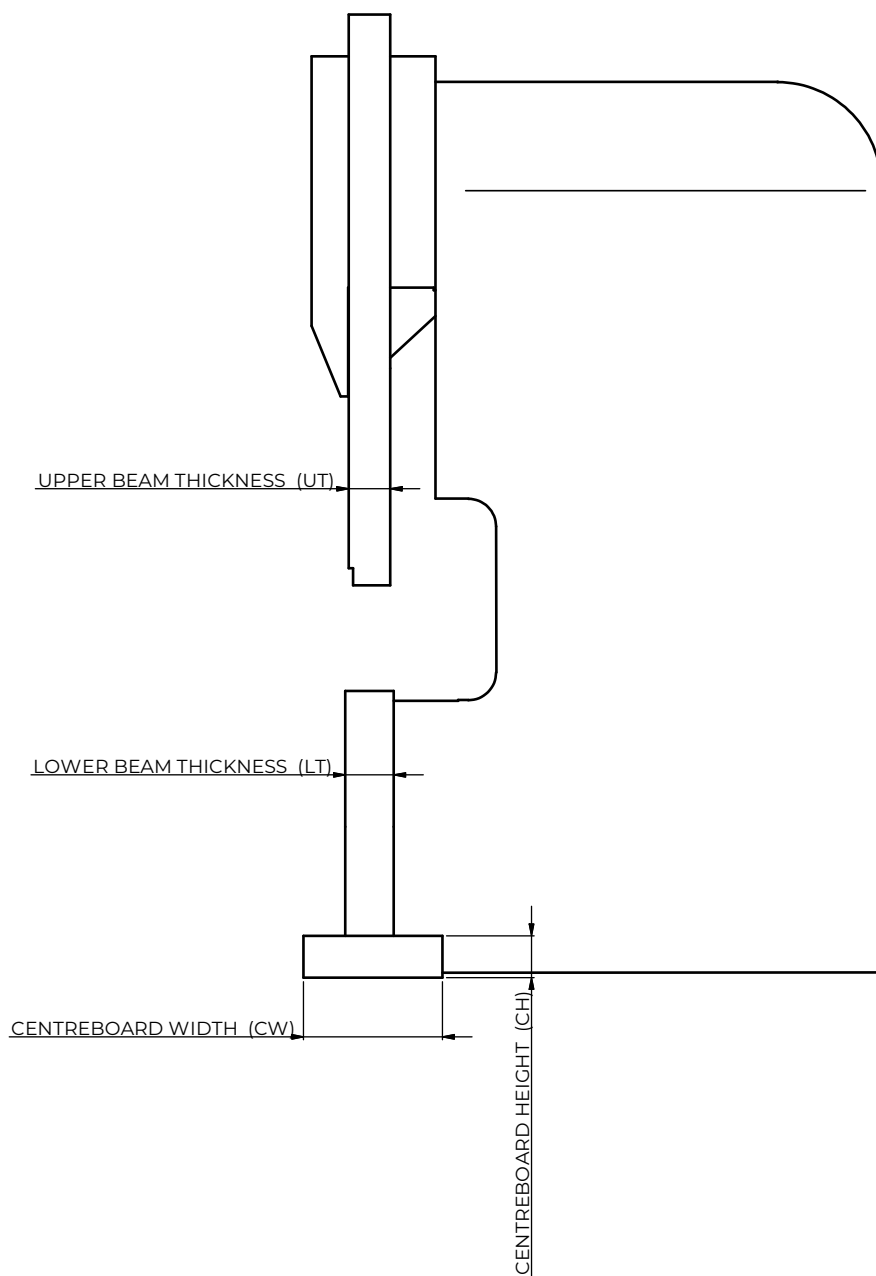

PRESS BRAKE DATA		
PRESS BRAKE TONNAGE		
UPPER BEAM		
DUB mm		
DC mm		
UL mm		
DF mm		
DUC mm		
UH mm		
UT mm		
DF mm		
LOWER BEAM		
DS mm		
CL mm		
TL mm		
DOC mm		
LH mm		
LT mm		
CW mm		(if present)
CH mm		(if present)

TAB



**SERVICES - ABOUT US**



---

Services

94

---

About us

95 - 97

---

COSTUMIZE YOUR  
CLAMPING!

 **ROLLERI**

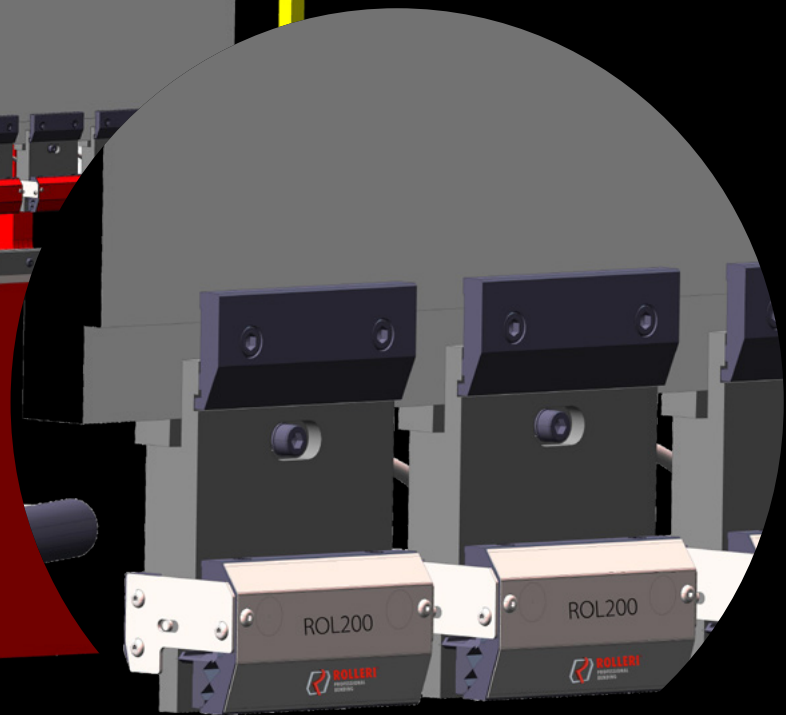
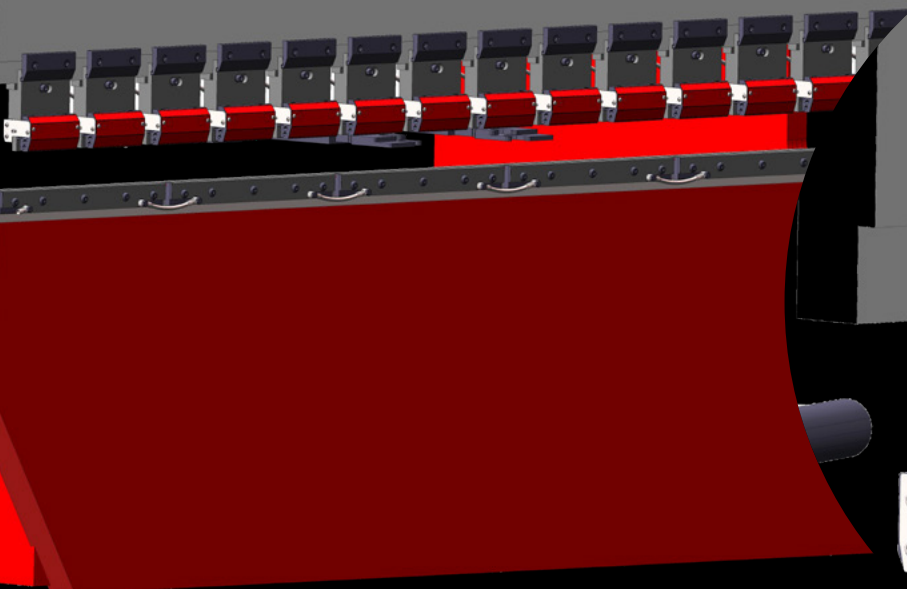
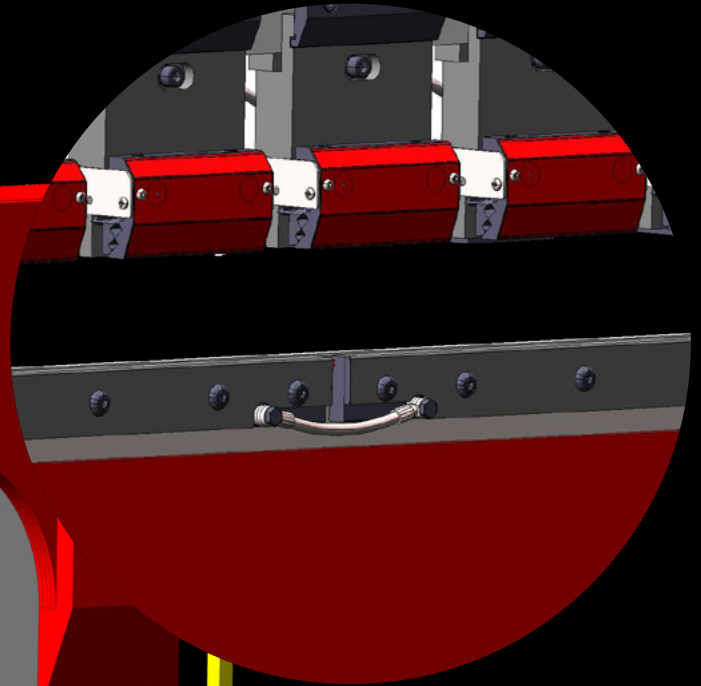



**THE COMPANY**

Born in 1987 as family-owned company, Rolleri SPA has become, in a few years, an important reference point for all those who deal with metal sheet bending. The combination of passion, dynamism, experience and research of new solutions have allowed the company to develop the brand internationally.

“We were born at the end of 80’s, with the idea to bring our tools throughout Italy, but over the years we exceed expectations” claim proudly Francesco and Marco Rolleri, owners of the company.

Rolleri SPA, located in the province of Piacenza, produces standard and special tools for press brakes and punching machines. Like today, thanks to the collaboration of trusted partners, it’s able to guarantee a coverage in each market and a fast and reliable service.

In 2016 the production capacity has further increased thanks to the purchase of a new establishment and the enlargement of the comprehensive machinery.

Rolleri is a leader in planning, development and production of press brake tools for the OE market and after-sales.

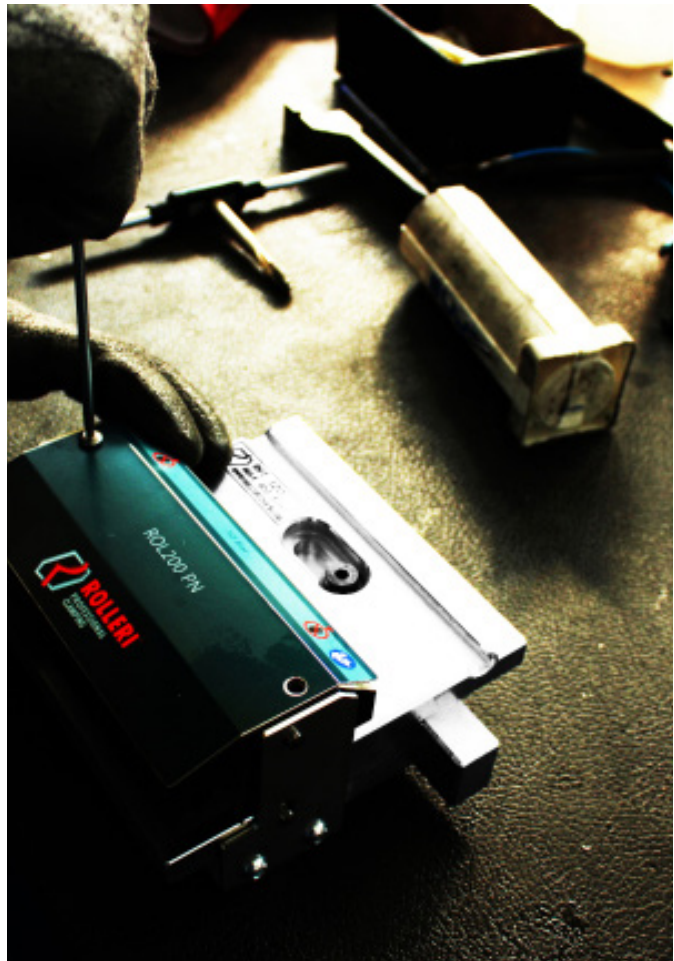

**ROLLERI WORLDWIDE**

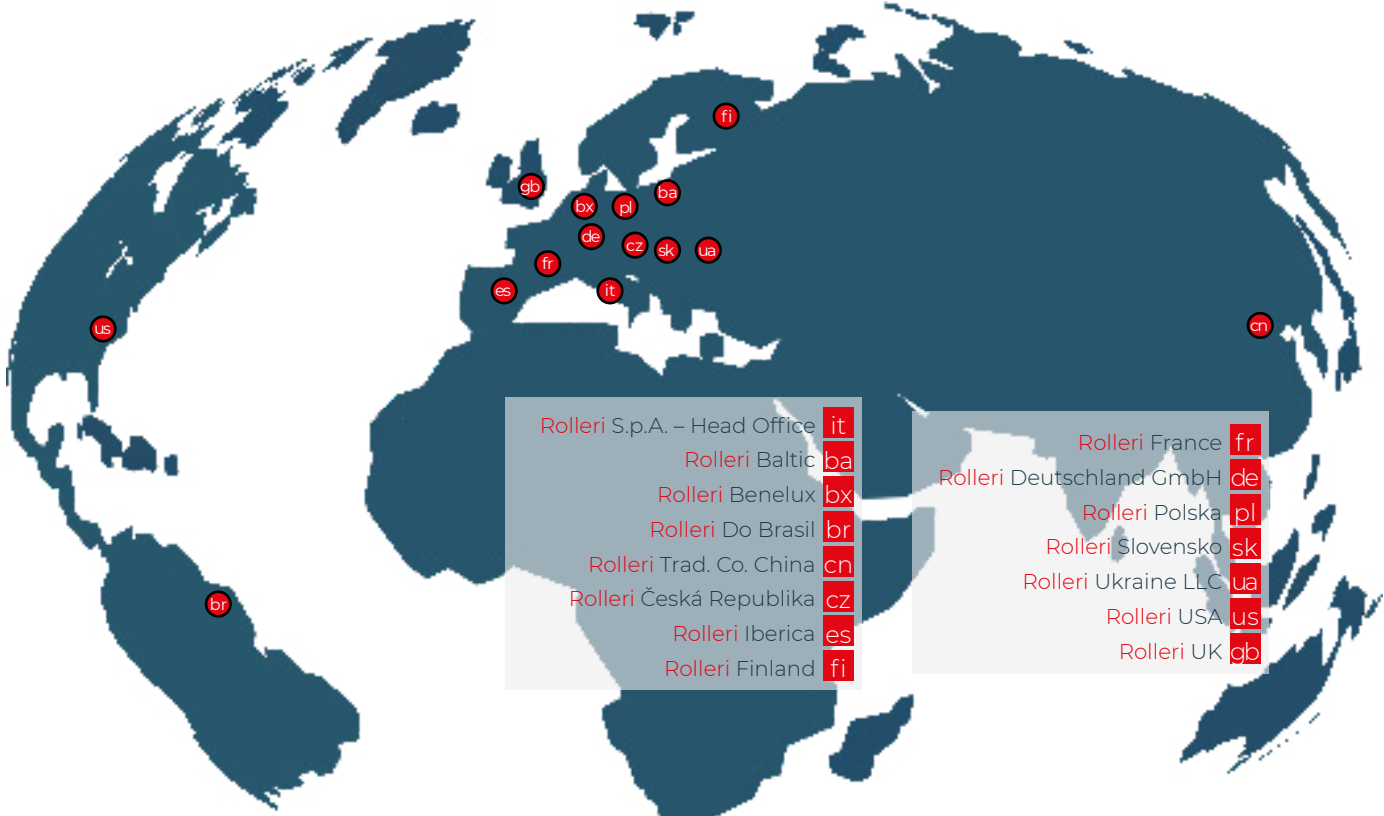





## OUR SUCCESS

Rolleri s.p.a success is the result of the synergy of commercial and marketing experiences developed during the years. Thanks to an "After Sales" strategy and a transparent price policy in all of our communication channels, the company acquired a growing number of end user customers.

Large investments in R&D allowed the creation of innovative Clamping systems and drew the attention of big OEMs, with whom we are collaborating. During 2017, the constant research of new products focused also on the materials used to create tools. This research brought us to "RollPrime 20.17": a new ultra-light material, ideal for tools dedicated to small batch production or prototyping.

Our range is constantly growing, constantly studying new systems that put us on the front line of researching new solutions for our customers.





## **www.rolleritools.com**

Visit us on our website and discover all products:

- Drawings 1:1 format available
- Extra information and tips
- Helpful videos and application examples
- Easy website browsing

### Copyright:

The use of Rolleri Publications and national adoptions of Rolleri Publications is subject to the user's acceptance of Rolleri's terms of use and conditions of copyright for Rolleri publications, as set out below.

All Rolleri Publications and national adoptions thereof are protected by copyright. Therefore and unless otherwise specified, no part of an Rolleri Publication or a national adoption thereof may be reproduced or utilized in any form or by any means, electronic or mechanical, including photocopying, micro film, and scanning, without permission in writing from the publisher.

SPECIAL HYBRID SYSTEM  
(Pneumatic and Hydraulic)  
500 Tons/meter



SPECIAL HYDRAULIC SYSTEM  
Axial tang  
250 Tons/meter





**КОВАЧЬ**  
www.kovach.pф

**WWW.ROLLERITOOOLS.COM**



**Официальный партнер  
«КОВАЧЬ»**

143405 · Московская область  
г. Красногорск · ул. Почтовая · д. 62/1  
Тел.: +7 (495) 215-21-75  
E-mail: info@kovach.pro  
www.kovach.pф

**Rolleri S.p.A.**

Via Artigiani · Loc. Cabina · 29020  
Vigolzone (PC) · Italy  
Tel. +39 05 23 87 09 05  
Fax +39 05 23 87 90 30  
E-Mail sales@rolleri.it  
Web www.rolleritools.com